

Outdoor SIP Emergency Call Service Solution

Out Door SIP Emergency Phone Solution

- AP-EIP60 Emergency IP Phone
- IPNext600 IP-PBX
- AP-IP300 IP Phone
- AP-NR1500 Network Recording Server
- Smart Digital Voice Recording Program
- Smart Network Management System

[Learn More >](#)

AddPac

AddPac Technology

Sales and Marketing

www.addpac.com

Contents

- IP Emergency Call Center Network Diagram
- Outdoor Emergency Call SIP Phone
- IPNext600 IP-PBX Solution for Call Center
- IP Phone Solution for Call Center
- IP Voice Recording Solution

Network Diagram

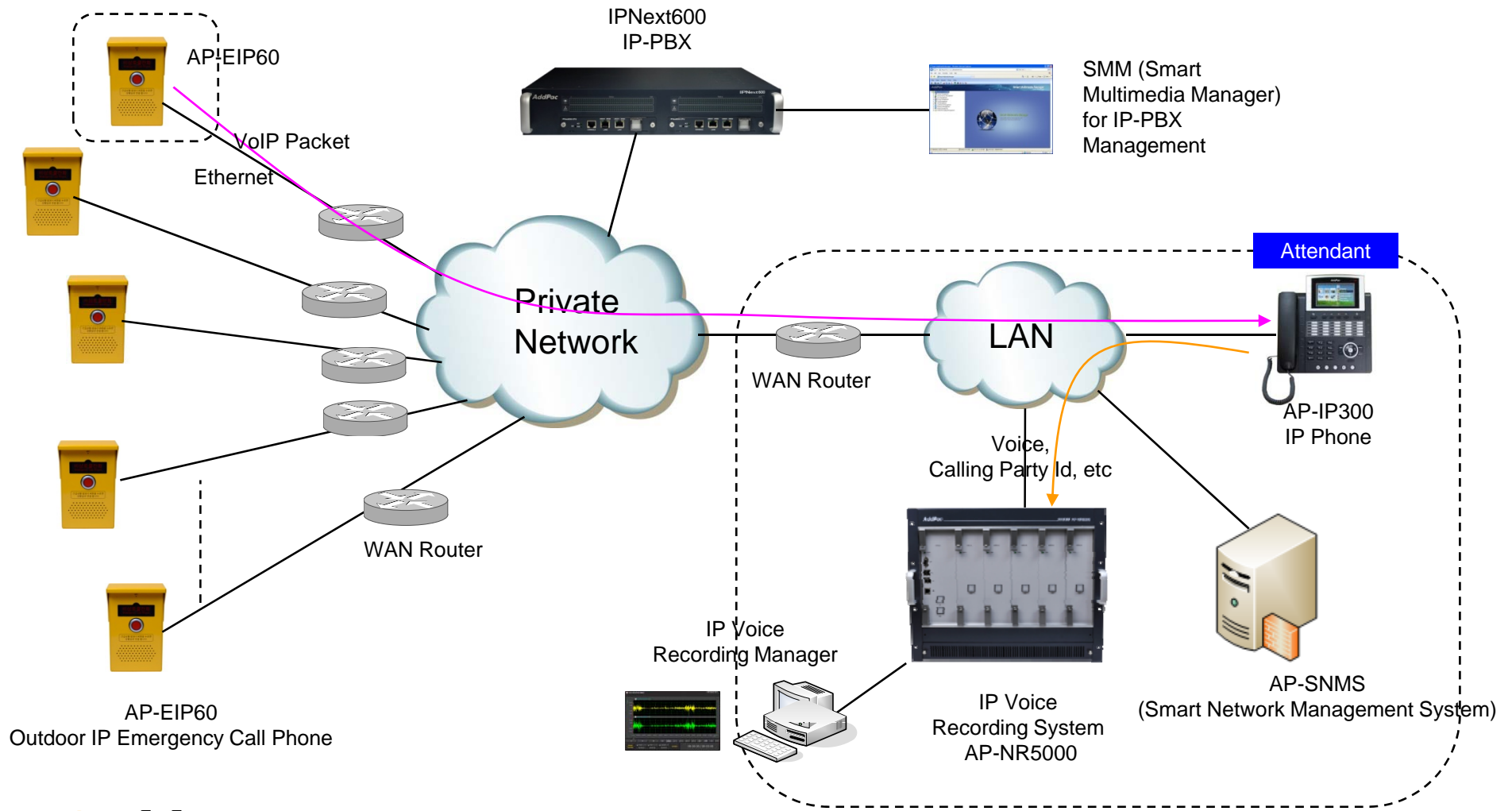



AP-EIP60 Outdoor Emergency Call SIP Phone

Product Overview

AP-EIP60 Emergency Call IP Phone

- High Performance Emergency Call IP Phone Solution
- Emergency Call IP Phone Solution for Outdoor Application
- Water Resistance Function Support
- Full Duplex Voice Communication
- One(1) 10/100Mbps Fast Ethernet
- PoE(Power over Ethernet) Support
- High Quality Speaker Phone Features
- SIP VoIP Signaling Stack Embedded
- Powerful Acoustic Echo Canceller Chip Embedded
- Powerful Network Protocols (PPPoE, DHCP, Static Routing, etc)
- Firmware Upgradeable Architecture
- Advanced Voice QoS Mechanism
- Die-Casting STILL Chassis

Hardware Specification

AP-EIP60 Emergency IP Phone

- RISC+DSP Microprocessor Computing Power
- Audio and Voice Interface
 - Internal MIC
 - Internal Speaker
- Emergency Call Button & LAMP
- Network Interface
 - One(1) 10/100Mbps Fast Ethernet
- Power Supply
 - Power over Ethernet (Option)
 - External Power Adaptor
- Cable (LAN, Power) Outlet (Option : Bottom or Backside)
- Die-Casting STILL Chassis

Hardware Specification

AP-EIP60 Emergency IP Phone

Front Side

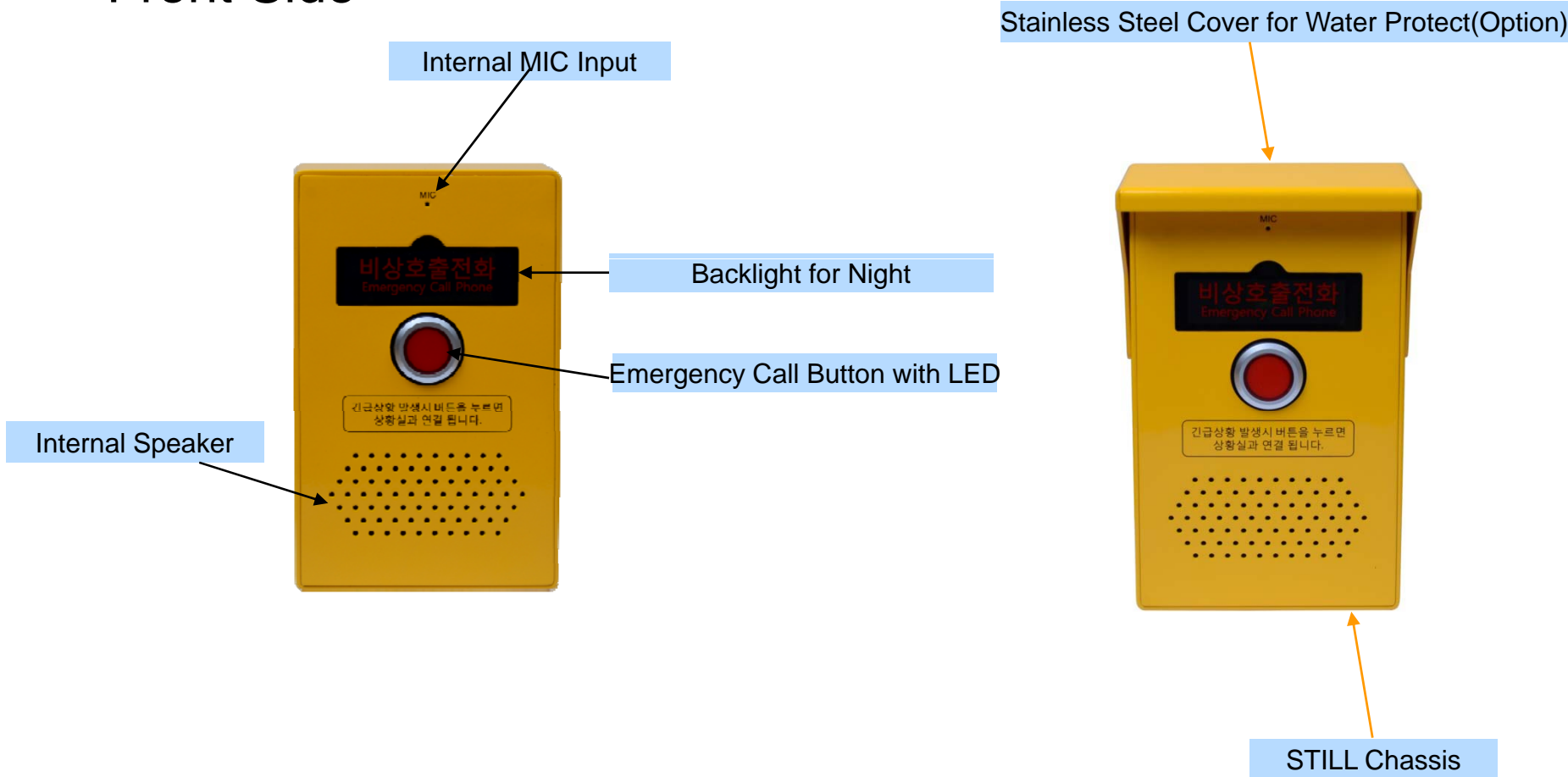

Hardware Specification

AP-EIP60 Emergency IP Phone

Back Side

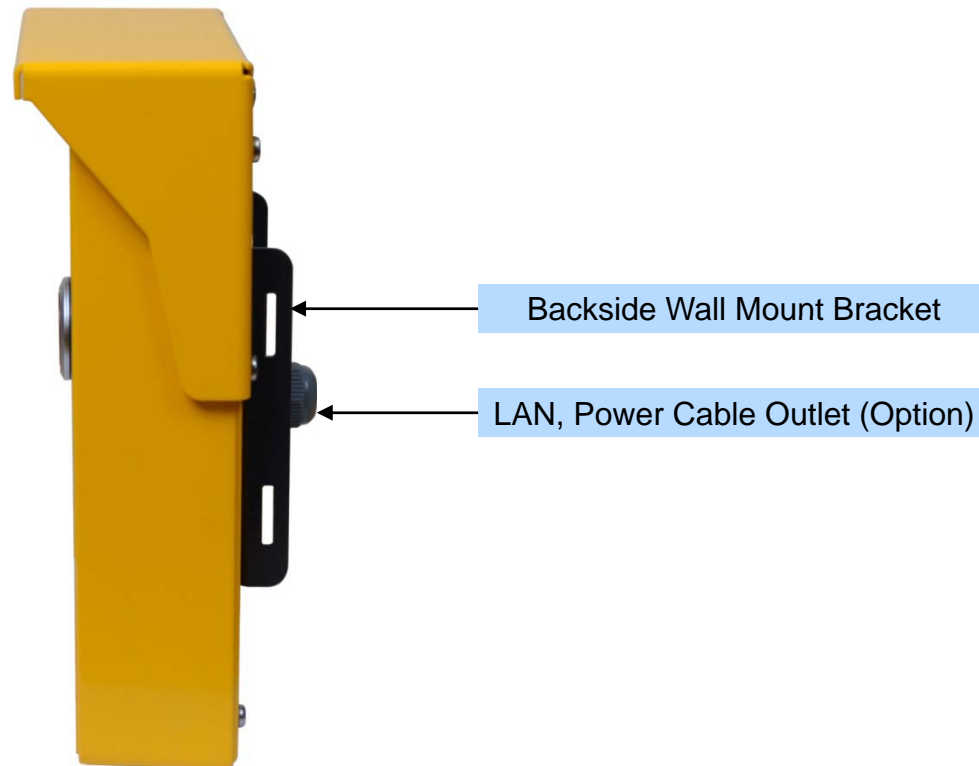



IPNext600 IP-PBX Solution for Call Center

Network Diagram

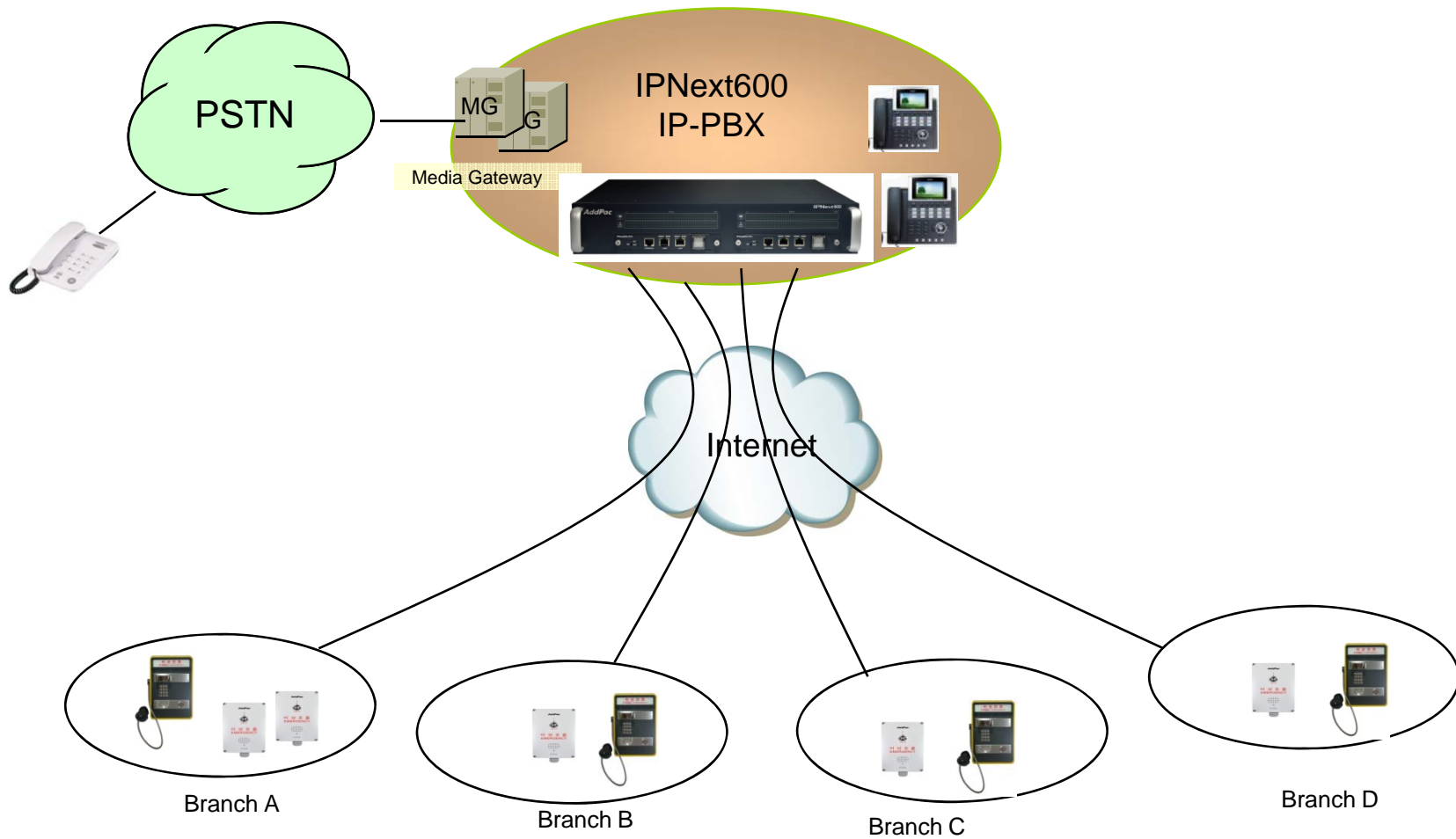

Product Overview

IPNext 600 Next Generation IP-PBX System

- SIP Application Server, Proxy, Registrar and Location Server
- Multiple ITSP Trunk with SIP & H.323 Accounts Support
- Dual System Redundancy Architecture
 - Two(2) Fast Ethernet Interface / System
- High Performance RISC Architecture
- Powerful Network Protocols (PPPoE, DHCP, Static Routing, etc)
- IPv4/IPv6 Dual Stack
- RTP Proxy Function Embedded for Private IP and IPv6 Address Interworking
- User Presence Service Features for Smart Multimedia Messenger and Smart IP Phone
- IVR Scenario Editor, Voice Mail, Media Service (Coloring), Conference
- Firmware Upgradeable Architecture
- Smart Multimedia Manager for IP-PBX Management
- Smart Messenger Service (click to dial) for Unified Communication
- Smart NMS for Large Scale Deployment
- Advanced Voice QoS Mechanism
- Dual Redundancy Power Module

Hardware Specification

IPNext 600 Next Generation IP-PBX System

RISC
CPU

IPNext 600 Front Side

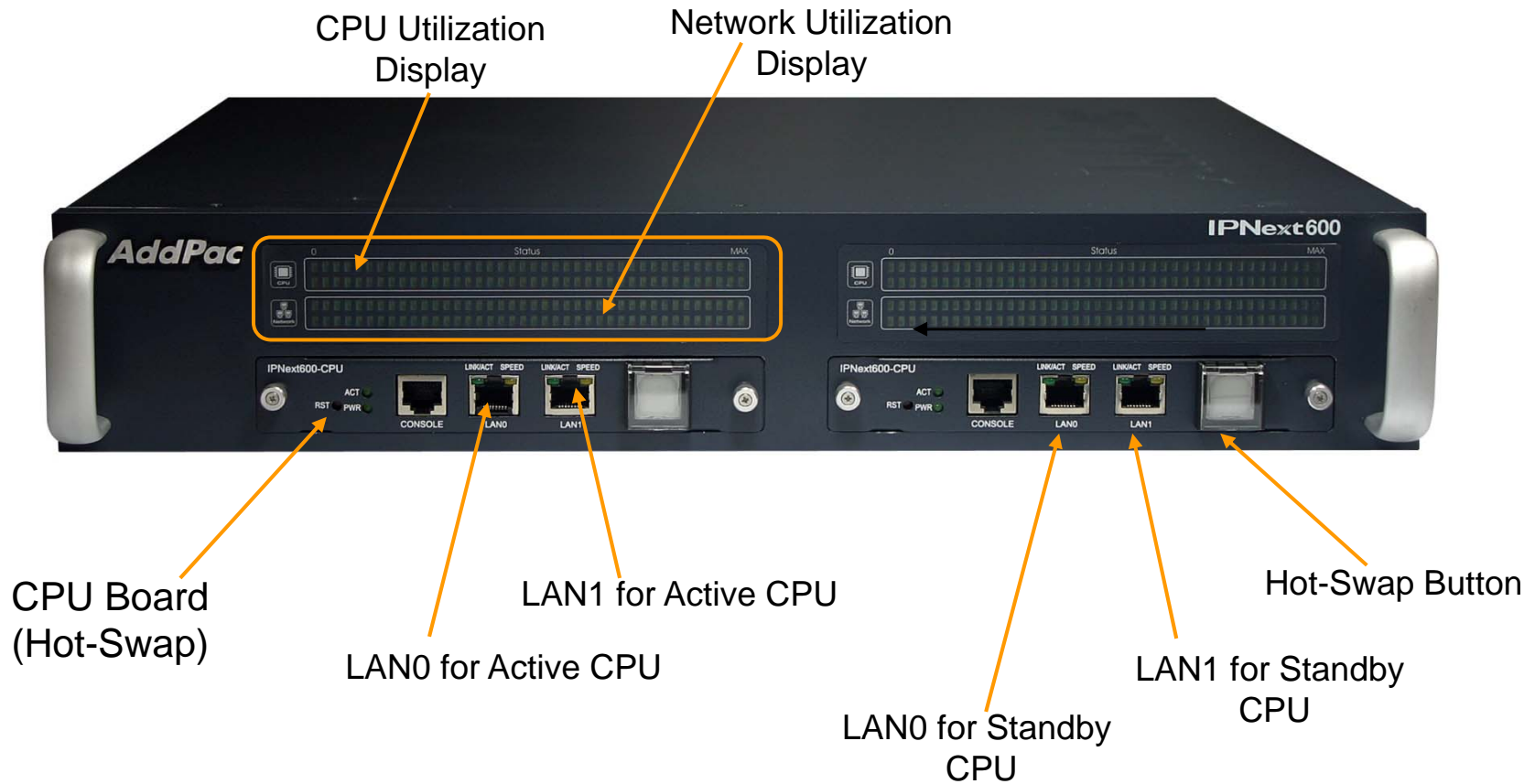

Hardware Specification

IPNext 600 Next Generation IP-PBX System



IPNext 600 Back Side

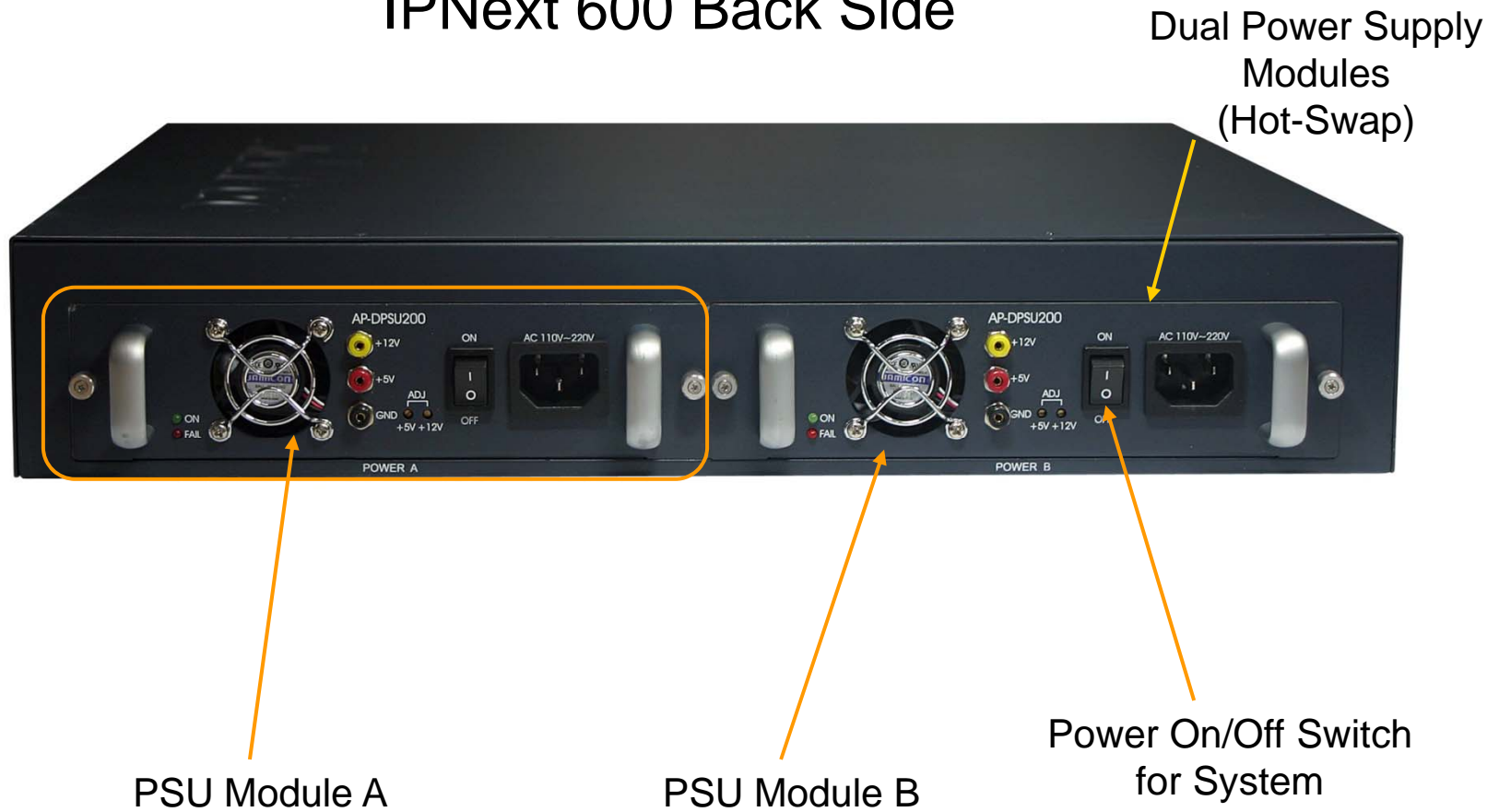

System Redundancy Features

IPNext 600 Next Generation IP-PBX System

IPNext600 System Block Diagram

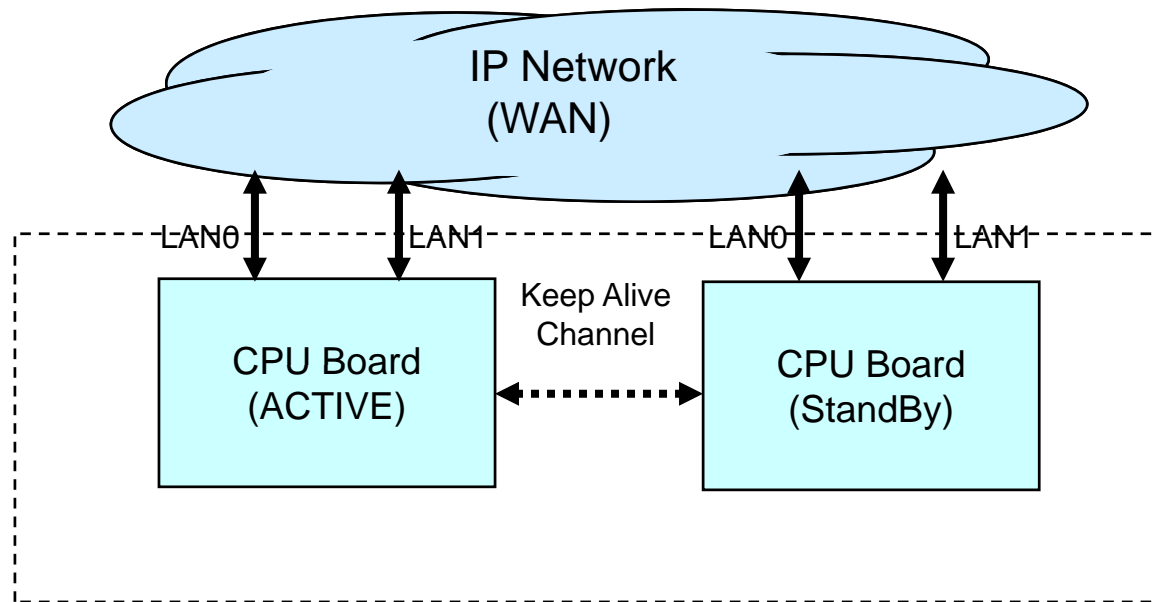

System Redundancy Features

IPNext 600 Next Generation IP-PBX System

- Active– Active Duplication Scheme
- Active – Standby Duplication Scheme
- VRRP based Duplication Scheme

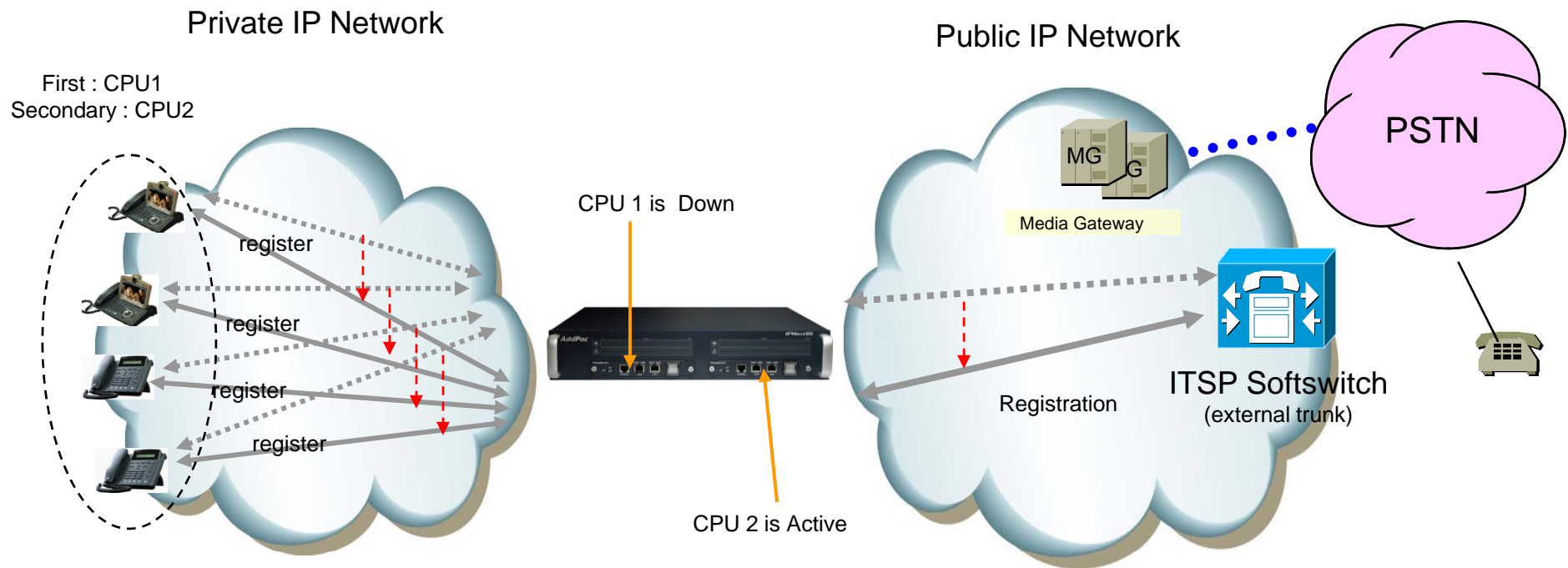



Active – Standby Duplication Scheme (example)



IP Phone Solution for Call Center

IP Phone Comparison Table

Model	AP-IP300	AP-IP230
Spec.		
LCD Size	4.3 Inch Color LCD	5 Inch Color LCD
Touch Screen	N/A	Support
Speed-Dial Keys	25 Key with Presence LED	Touch Screen based 25 Keys
Voice Codec	G.711/G.726/ G.729/G.723	G.711/G.726/ G.729/G.723
Signaling	H.323/SIP	H.323/SIP
3-Party Conversation	Support	Support
LAN Port	2	2
PoE(Optional)	Support	Support
FXO(Optional)	Support	Support



IP Voice Recording Solution

Contents

- IP Voice Recording Servers
- Network Diagram for Voice Recording
- SIP Voice Call Flow Diagram
- Smart Digital Voice Recording Management Program



IP Voice Recording Server AP-NR5000

Product Overview

AP-NR5000 IP Voice Recording Server

- IP based Voice Recording Server
- Linux Operating System
- Powerful Management and User Friendly Features
- High-performance Voice/Video Recording Service
- External IP Phone (AP-IP300, AP-IP230, etc) Interworking Support
- Firmware Upgradeable Architecture
- One(1) 10/100/1000Mbps Gigabit Ethernet Interface
- Up to Five(5) 3.5Inch SATA Hard Disk Interface Support
- USB Interface Support

Hardware Specification

AP-N5000 IP Voice Recording Server

- High Performance Computing Power
- Main Processor Board
 - Network Interface
 - One(1) 10/100/1000Mbps Gigabit Ethernet
 - Video Output Interface
 - RGB Video Output
 - USB 2.0 Interfaces for Mouse, Keyboard, etc
- Hard Disk Board
 - Module Type Design
 - Up Five(5) Hard Disk Slots
 - 10~20 Tera HDD Capacity
- Power Supply
 - Dual Power Supply for Power Redundancy
 - Module Type Power Supply

Hardware Specification

AP-NR5000 IP Voice Recording Server

AP-NR5000 Front Side

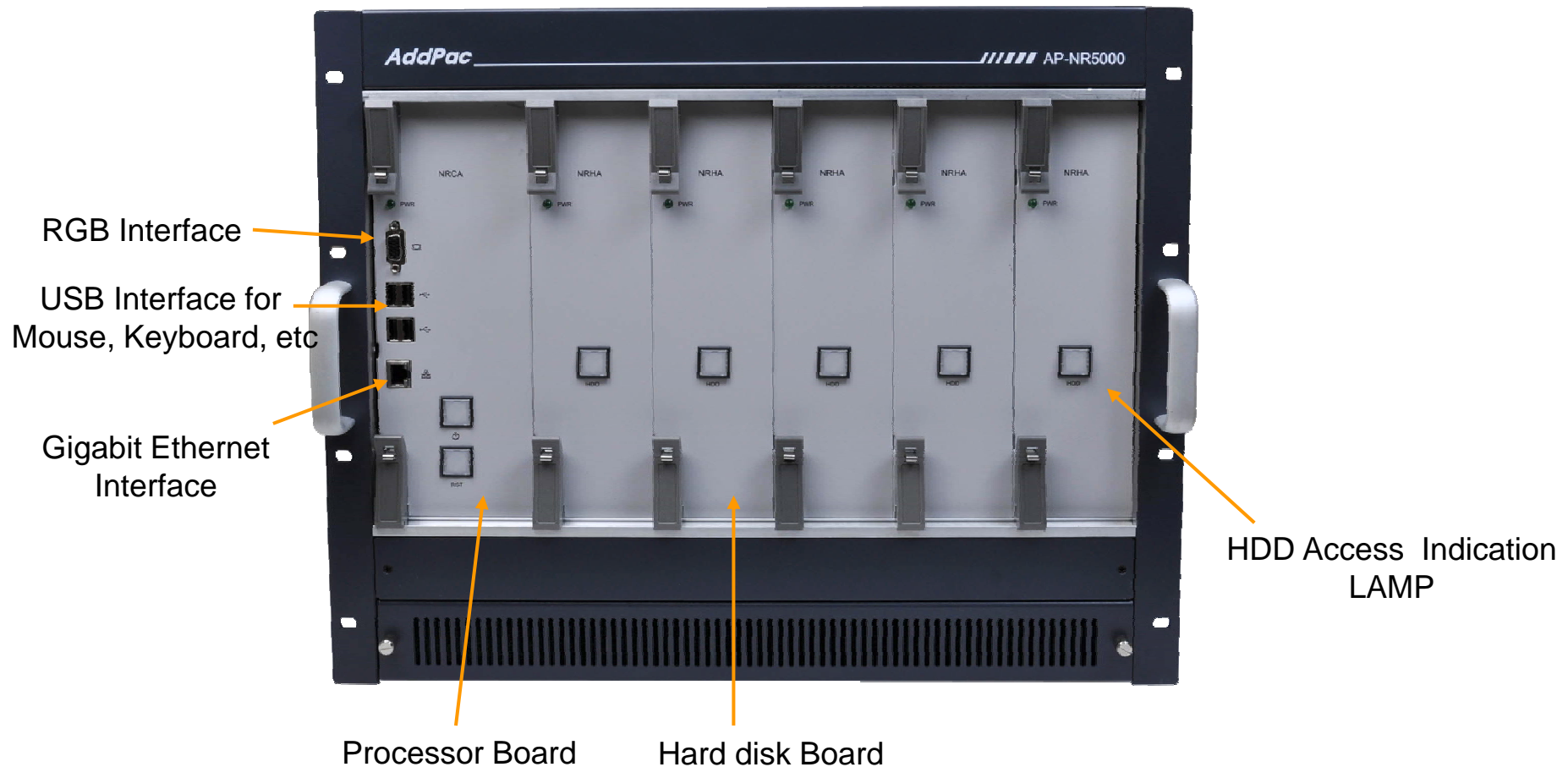

Hardware Specification

AP-NR5000 IP Voice Recording Server

AP-NR5000 Back Side

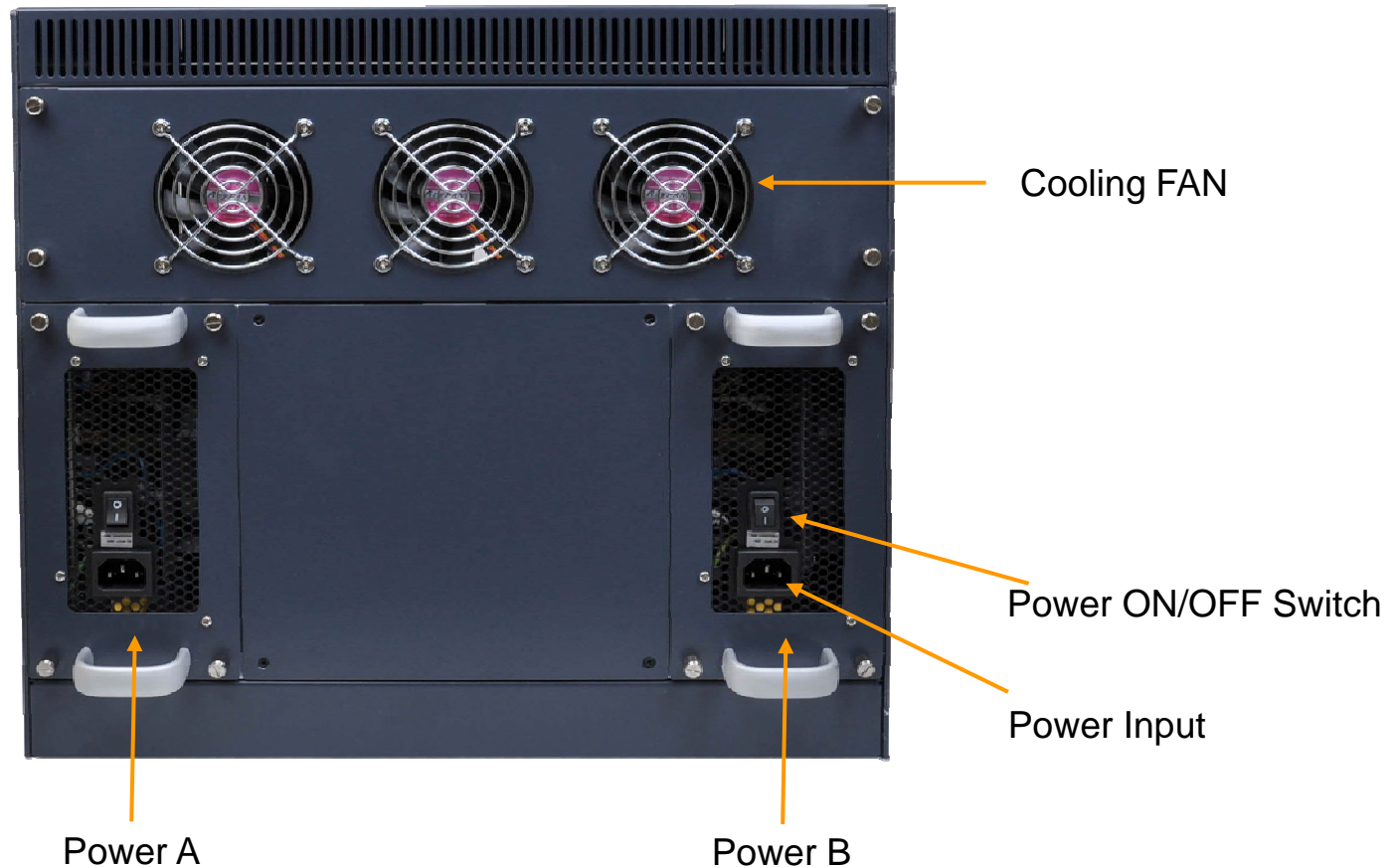



IP Voice Recording Server AP-NR1500

Product Overview

AP-NR1500 IP Voice Recording Server

- IP based Network Voice Call Recording Server
- Linux Operating System
- Powerful Management and User Friendly Features
- High-performance Voice Recording Service
- External AddPac IP Terminal (Ex: IP Phone, IP Intercom, IP Emergency Phone) Interworking Support
- Firmware Upgradeable Architecture
- One(1) 10/100/1000Mbps Gigabit Ethernet Interface
- Up to Two(2) 3.5Inch SATA Hard Disk Interface Support
- Two(2) USB Interface Support
- One(1) RS232C Console Interface

Hardware Specification

AP-N1500 IP Voice Recording Server

- High Performance Computing Power
- Network Interface
 - One(1) 10/100/1000Mbps Gigabit Ethernet Port
- Two(2) USB 2.0 Interfaces for Mouse, Secondary Storage, etc
- One(1) RS232C Console Interface (RJ45)
- Up Two(2) SATA type Hard Disk (4~8 Tera HDD Capacity)
- Power On/Off Soft Switch with LED Indication Lamp (Front Side)

Hardware Specification

AP-NR1500 IP Voice Recording Server

AP-NR1500 Front Side



Power On/Off Switch with LED Indication LAMP

Hardware Specification

AP-NR1500 IP Voice Recording Server

AP-NR1500 Back Side

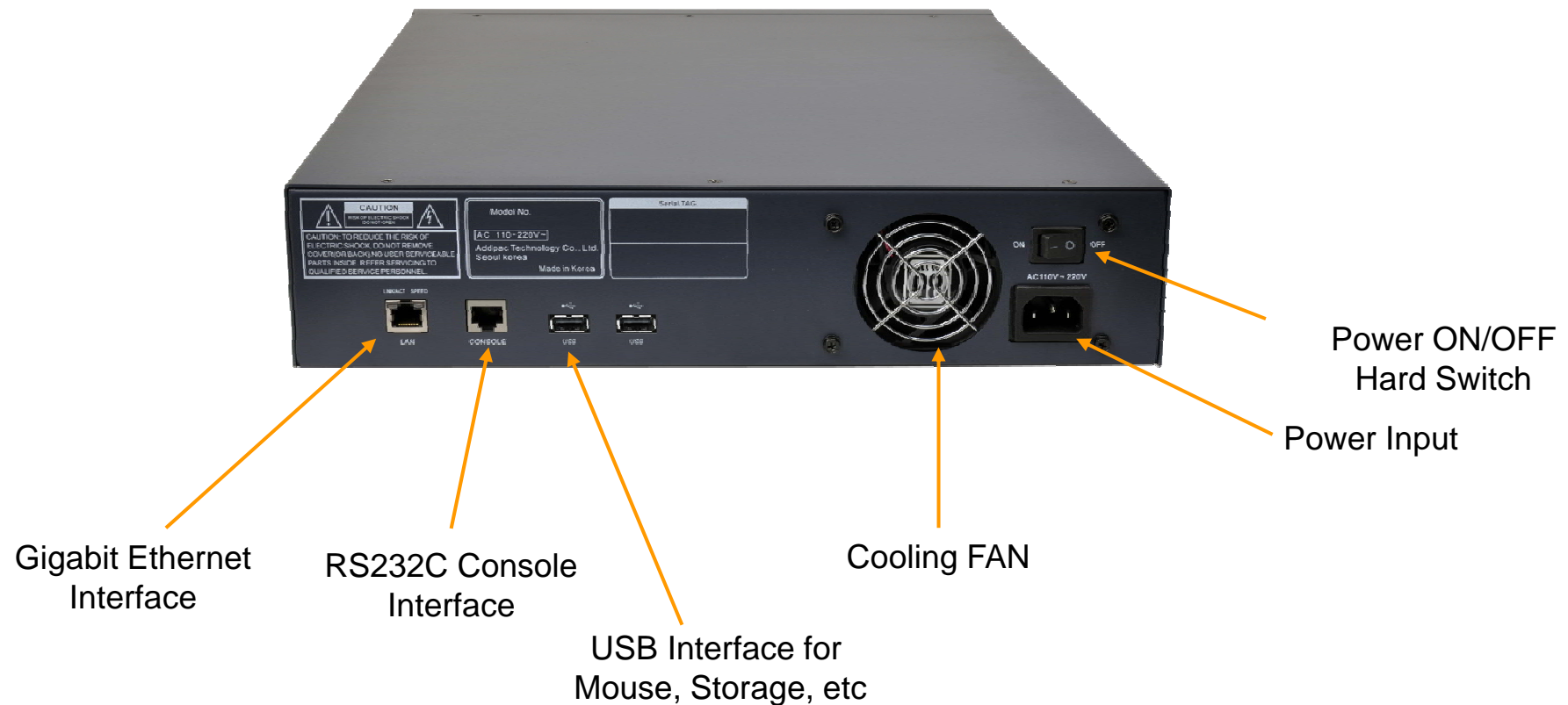

Network Diagram for IP Phone Recording

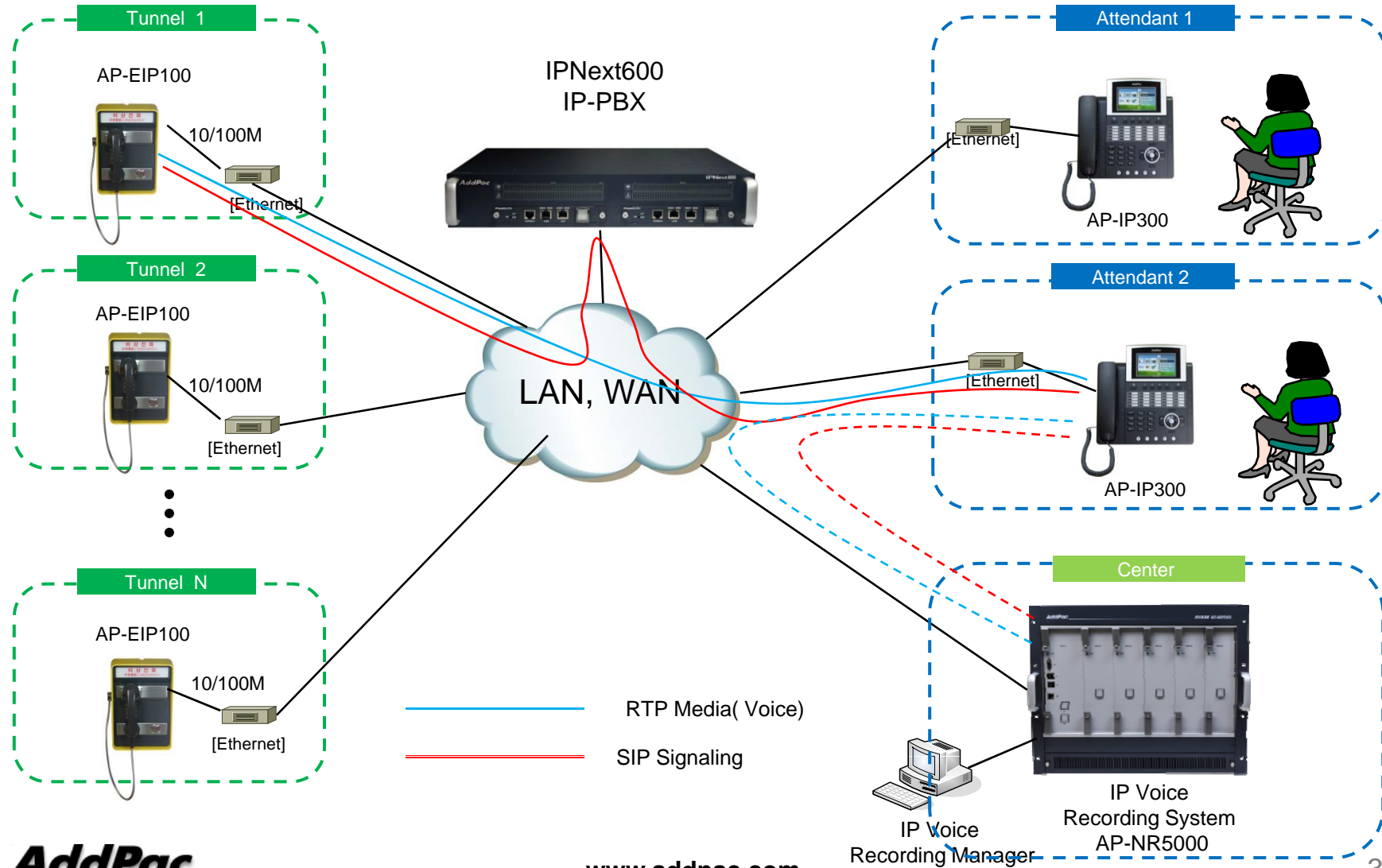

SIP VoIP Call Flow

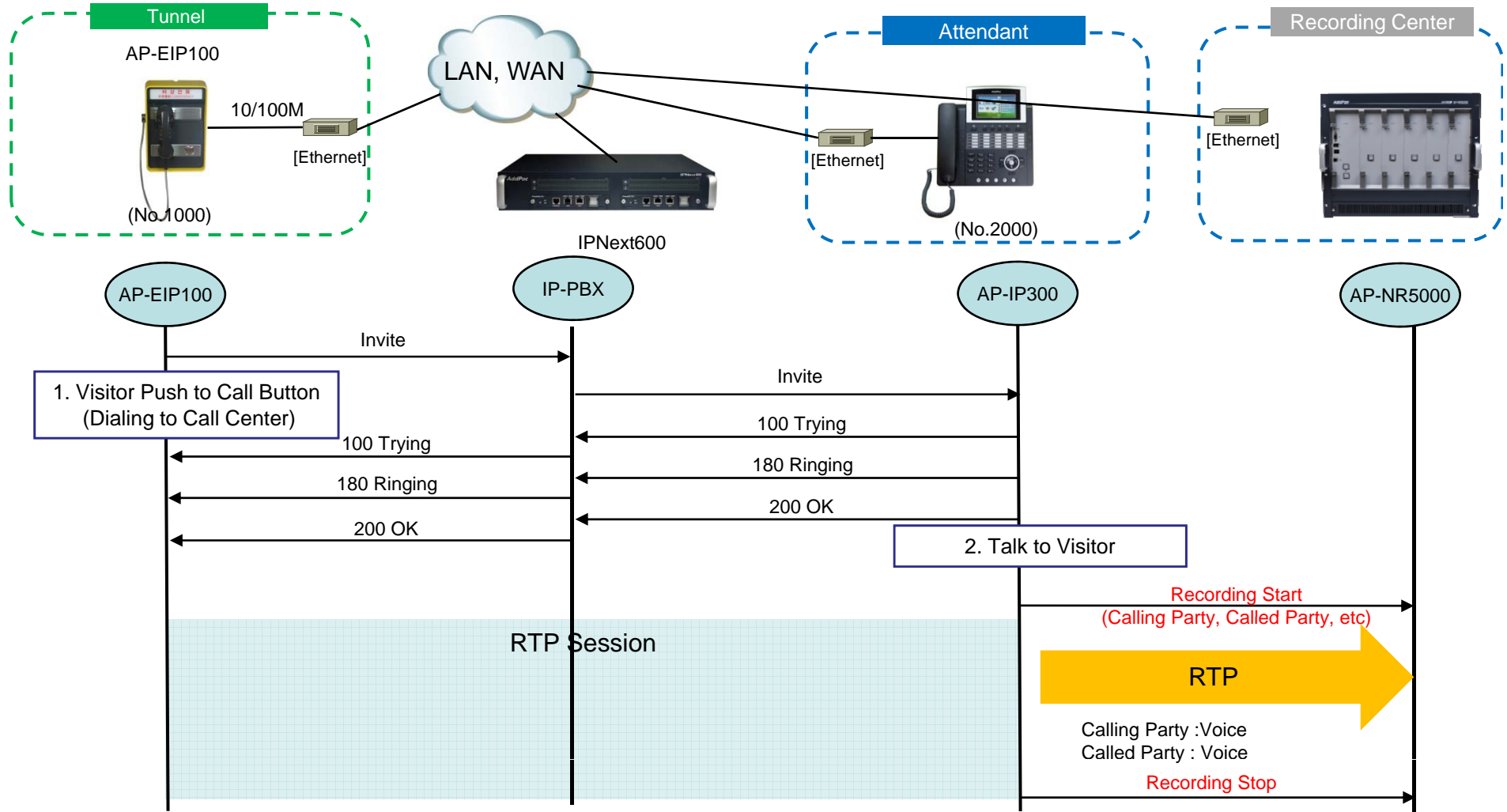



Smart DVoiceR Manager

Smart DV_{ideo} door phoneR Management Program

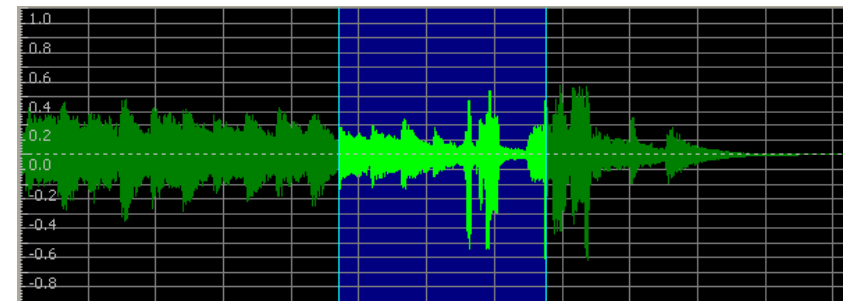
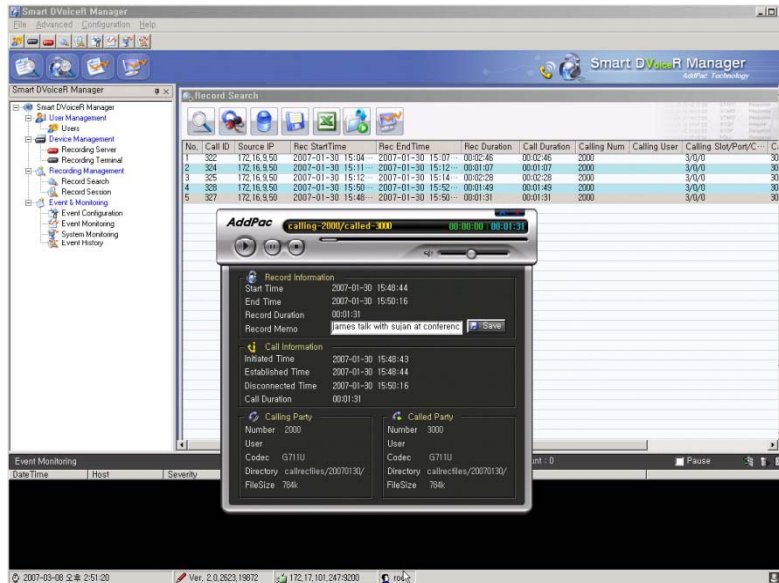

- Call History Management (search/modify/delete/save)
- Media Play Management (Play/Stop/Seek/Pause)
- Live Call List Management, Live Call Monitoring
- Local Backup (File Manager Support, PC HDD, DVD) and Local Play
- User Management (registration/modify/delete/search)
- Server Status (CPU/Memory/HDD) & Event Monitoring
- Recording Source Management (Video Phone, etc)
- Live Recording Board

UI example (recording file search..)

Recording File Search Result

Calling Num ▼ 9000 Search

	Calling Number	Called Number	Recording Start Time	Recording End Time	Duration (sec)	Play
<input type="checkbox"/>	9000	5000	2010/03/17 09:50:45	2010/03/17 09:51:45	60	Play
<input checked="" type="checkbox"/>	9000	3000	2010/03/18 09:00:12	2010/03/17 09:00:45	33	Play
<input checked="" type="checkbox"/>	9002	9000	2010/03/18 10:50:12	2010/03/17 10:55:12	300	Play
<input type="checkbox"/>	9005	9000	2010/03/18 15:12:03	2010/03/18 15:12:13	10	Play
<input type="checkbox"/>	9006	9000	2010/03/19 01:10:23	2010/03/19 01:11:10	47	Play

[1] [2] [3] ... [Next]

Backup

Powerful Recording Search
* calling number
* called number
* date
* call identifier, etc

Recording Play

Recording Backup
* selected files from recording server to PC storage

Calling Number : Video Door Phone
Called Number : Video Phone (attendant)

Login

The image shows the 'Smart DVoiceR Manager' login screen. At the top, it says 'AddPac Technology' and 'Smart DVoiceR Manager USER LOGIN'. There are two input fields: 'ID' with 'root' and 'Password' with '*****'. To the right are 'Login' and 'Setting' buttons. Below the password field are two checkboxes: 'Auto login' (unchecked) and 'Save password' (checked). A 'Setting' dialog box is open, titled 'Setting', with a 'Smart Recording Server' section containing 'IP Address' (172.16.4.22) and 'Port' (9200, default: 9200). 'OK' and 'Cancel' buttons are at the bottom of the dialog. Red arrows point from the 'Auto login' checkbox to the text 'Auto Login Configuration' and from the 'Save password' checkbox to the text 'Password Save'.

Auto Login Configuration

Password Save

Setting

Smart Recording Server

IP Address 172.16.4.22

Port 9200 (default: 9200)

OK Cancel

User Management

The screenshot shows the Smart DVoiceR Manager application window. The main window title is "Smart DVoiceR Manager" and it has a menu bar with "File", "Advanced", "Configuration", and "Help". Below the menu bar is a toolbar with various icons. The main content area is titled "Smart DVoiceR Manager" and "AddPac Technology". On the left is a tree view showing the application structure, with "User Management" expanded to show "Users".

Three red arrows point to icons in the "Users" window:

- New Manager Registration** points to the "Add" icon (a person with a plus sign).
- Manager Information Modification** points to the "Edit" icon (a person with a pencil).
- Manager Delete** points to the "Delete" icon (a person with a minus sign).

The "Users" window displays a table with the following data:

No.	ID	Name	Description
1	Administrator	Administrator	Addpac Administrator
2	root	recording manager	Maintenance dept.

The status bar at the bottom shows the date and time "2007-06-13 오후 1:43:49", the version "Ver. 1.0.2719", the IP address "172.16.31.14:9200", and the user "root".

Recording Server Status Monitoring

Smart DVoiceR Manager

File Advanced Configuration Help

Smart DVoiceR Manager

- Smart DVoiceR Manager
 - User Management
 - Users
 - Device Management
 - Smart Recording Server**
 - Smart Recording Terminal
 - Recording Management
 - Record Search
 - Record Session
 - Event & Monitoring
 - Event Configuration
 - Event Monitoring
 - System Monitoring
 - Event History
 - Recording Board
 - Board Users
 - Board Groups
 - Map List

Smart Recording Server

Smart Recording Server Status

172.16.31
Smart Re

Configuration Client Session List

Max Session : 10

Keep Alive Interval : 15 sec

OK

Smart Recording Server

Smart Recording Server Status

172.16.31,14:9200
Smart Recording Server is running.

Configuration Client Session List

No.	User	IP Address	Port	Access Time	Duration
1	root	172.16.1.31	4417	2007-06-13 13:40:05	00:04:49

Client List

OK Cancel

2007-06-13 오후 1:46:20 Ver. 1.0.2719 172.16.31,14:9200 root

Recording File Management

(Recorded File Monitoring (play/seek/pause/resume/stop))

The screenshot displays the Smart DVoiceR Manager software interface. The main window shows a 'Record Search' table with columns for No., Call ID, Source IP, Rec StartTime, Rec EndTime, Rec Duration, Call Duration, Calling Num, Calli..., Calling..., Called Num, Calle..., and Called S... The table contains 19 rows of recording data. A 'Search Filter' dialog box is open, showing search criteria for Record Time (Start Time: 2007-06-14 00:00:00, End Time: 2007-06-14 23:59:59) and Filter Name (Calling Number, Called Number, etc.). A recording playback window is overlaid on the table, showing 'AddPac calling-3004/called-5020' with a progress bar and a 'Memo Save' button. The playback window also displays recording information, call information, and calling/called party details.

No.	Call ID	Source IP	Rec StartTime	Rec EndTime	Rec Duration	Call Duration	Calling Num	Calli...	Calling...	Called Num	Calle...	Called S...
1	39500	172.17.213.100	2007-06-13 13:12:15	2007-06-13 13:12:43	00:00:28	00:00:28	3000		4/0/0	5016		4/0/0
2	39502	172.17.213.100	2007-06-13 13:12:15	2007-06-13 13:12:43	00:00:28	00:00:28	3001		4/1/0	5017		4/1/0
3	39504	172.17.213.100	2007-06-13 13:12:15	2007-06-13 13:12:43	00:00:28	00:00:28	3002		4/2/0	5018		4/2/0
4	39506	172.17.213.100	2007-06-13 13:12:15	2007-06-13 13:12:43	00:00:28	00:00:28	3003		4/3/0	5019		4/3/0
5	39508	172.17.213.100	2007-06-13 13:12:15	2007-06-13 13:12:44	00:00:28	00:00:28	3004		5/0/0	5020		5/0/0
6	39510	172.17.213.100	2007-06-13 13:12:15	2007-06-13 13:12:44	00:00:28	00:00:28	3005		5/1/0	5021		5/1/0
7	39512	172.17.213.100	2007-06-13 13:12:15	2007-06-13 13:12:45	00:00:29	00:00:28	3006		5/2/0	5022		5/2/0
8	39514	172.17.213.100	2007-06-13 13:12:15	2007-06-13 13:12:45	00:00:29	00:00:28	3007		5/3/0	5023		5/3/0
9	39516	172.17.213.100	2007-06-13 13:12:15	2007-06-13 13:12:45	00:00:29	00:00:28	3007		5/3/0	5023		5/3/0
10	39518	172.17.213.100	2007-06-13 13:12:15	2007-06-13 13:12:45	00:00:29	00:00:28	3007		5/3/0	5023		5/3/0
11	39520	172.17.213.100	2007-06-13 13:12:16	2007-06-13 13:12:16	00:00:00	00:00:00				5024		6/0/0
12	39522	172.17.213.100	2007-06-13 13:12:16	2007-06-13 13:12:16	00:00:00	00:00:00				5025		6/1/0
13	39524	172.17.213.100	2007-06-13 13:12:16	2007-06-13 13:12:16	00:00:00	00:00:00				5026		6/2/0
14	39526	172.17.213.100	2007-06-13 13:12:17	2007-06-13 13:12:17	00:00:00	00:00:00				5027		6/3/0
15	39528	172.17.213.100	2007-06-13 13:12:17	2007-06-13 13:12:17	00:00:00	00:00:00				5028		7/0/0
16	39529	172.17.213.100	2007-06-13 13:12:17	2007-06-13 13:12:17	00:00:00	00:00:00				5029		7/1/0
17	39498	172.17.213.100	2007-06-13 13:12:17	2007-06-13 13:12:17	00:00:00	00:00:00				5030		7/2/0
18	39499	172.17.213.100	2007-06-13 13:12:17	2007-06-13 13:12:17	00:00:00	00:00:00				5031		7/3/0
19	39501	172.17.213.100	2007-06-13 13:12:17	2007-06-13 13:12:17	00:00:00	00:00:00				2000		0/0/0
										2001		0/1/0
										2002		0/2/0
										2003		0/3/0
										2004		1/0/0
										2005		1/1/0
										2006		1/2/0
										2007		1/3/0
										2008		2/0/0
										2009		2/1/0
										2010		2/2/0
										2011		2/3/0
										2013		3/1/0
										2014		3/2/0
										2015		3/3/0
										2012		3/0/0
										5016		4/0/0
										5017		4/1/0

Recording File List Save (Excel File Format)

The screenshot displays the Smart DVoiceR Manager interface. The 'Record Search' window shows a list of recording entries. A dialog box titled '다른 이름으로 저장' (Save As) is open, showing the file name 'Records.xls' and the format 'Excel Files'. A progress bar indicates that 69% of the records are being exported. A 'Records Exporting !!!' dialog box is also visible, with a 'Cancel' button.

No.	Call ID	Source IP	Rec StartTime	Rec EndTime	Rec
1	63292	172.16.9.60	2007-06-12 09:44:59	2007-06-12 09:46:34	00:01:35
2	63293	172.16.9.60	2007-06-12 09:46:38	2007-06-12 10:10:38	00:22:49
3	63295	172.16.9.60	2007-06-12 10:11:28	2007-06-12 10:14:34	00:03:06
4	64171	172.16.9.60	2007-06-12 13:24:09	2007-06-12 13:24:09	00:00:00
5					
6					
7					
8	64177	172.16.9.60	2007-06-12 14:04:09	2007-06-12 14:04:25	00:00:16
9	64181	172.16.9.60	2007-06-12 14:05:11		
10	64185	172.16.9.60	2007-06-12 14:34:21		
11	64186	172.16.9.60	2007-06-12 14:37:31		
12	67503	172.16.9.60	2007-06-12 16:00:00		
13	67504	172.16.9.60	2007-06-12 16:02:51		
14	67515	172.16.9.60	2007-06-12 17:03:21		
15	67517	172.16.9.60	2007-06-12 17:06:00		

Recording File Waveform Analyzer

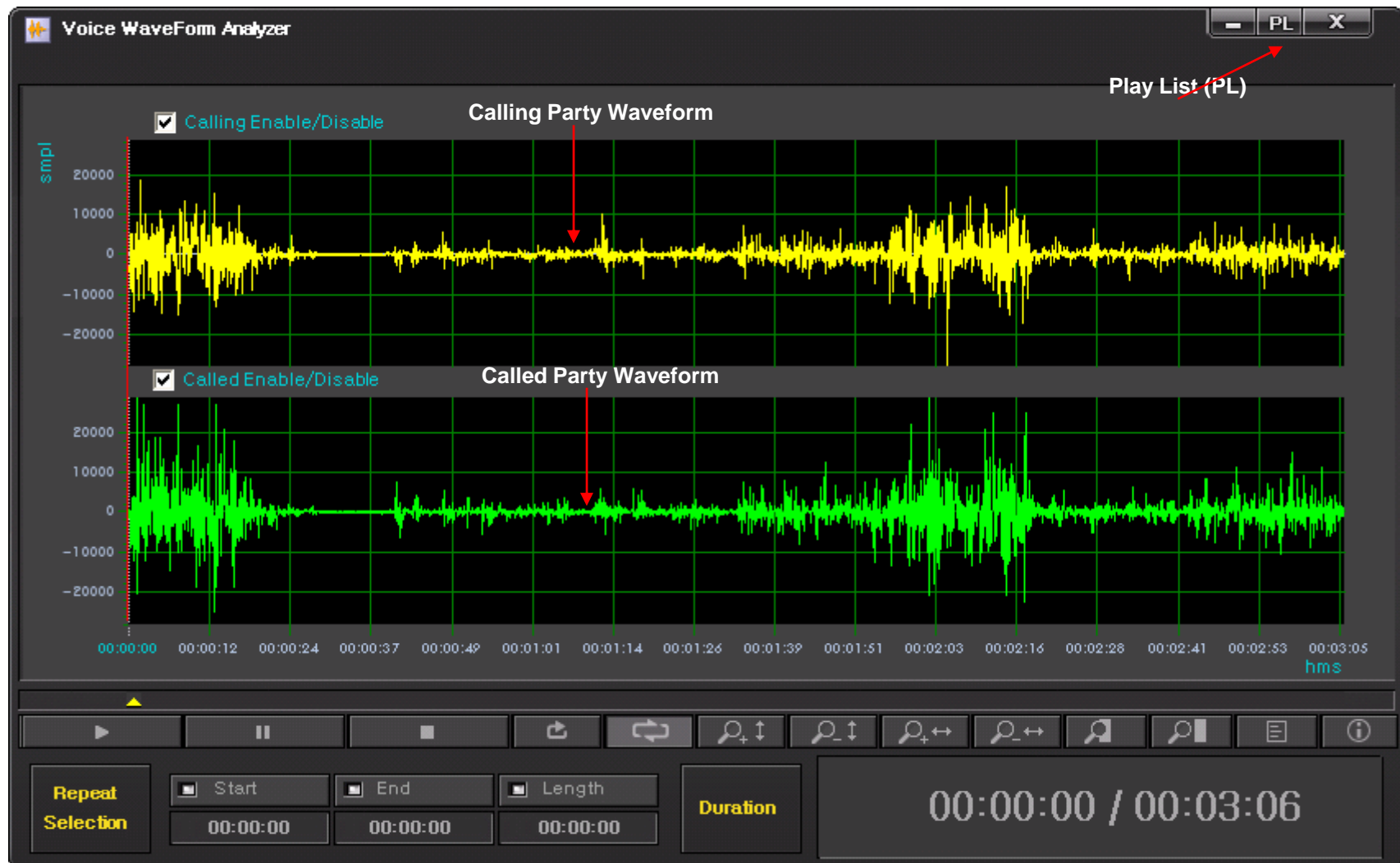

Recording File Waveform Analyzer

(Repeated Play)



Recording File Waveform Analyzer

(Bookmark Play)

The screenshot displays the 'Voice WaveForm Analyzer' interface. It features two waveform plots: the top one is yellow and the bottom one is green. Both plots have a vertical axis labeled 'smpl' ranging from -20000 to 20000 and a horizontal axis with time markers from 00:00:00 to 00:03:05. The top plot has checkboxes for 'Calling Enable/Disable' and 'Called Enable/Disable'. A 'Bookmark Set' label points to a specific time on the top waveform. A 'Bookmark' label with a pushpin icon points to a specific time on the bottom waveform. A 'Play at Bookmark Position' label points to a time on the bottom waveform. A 'Bookmark List' dialog box is open, showing a table with columns 'No.', 'Name', and 'Time'. The table contains one entry: '1', 'my bookmark no1.', '00:01:05'. The dialog has buttons for 'Modify', 'Bookmark Set', 'Bookmark Delete', and 'Bookmark List'. A 'Play From Here' context menu is open over the bottom waveform, with options 'Set Bookmark' and 'Bookmark List'. The bottom of the interface includes a control bar with play, pause, stop, and other icons, and a 'Bookmark List' section showing '00:00:00 / 00:03:06'.

No.	Name	Time
1	my bookmark no1.	00:01:05

Recording File Waveform Analyzer

(Region Zooming)

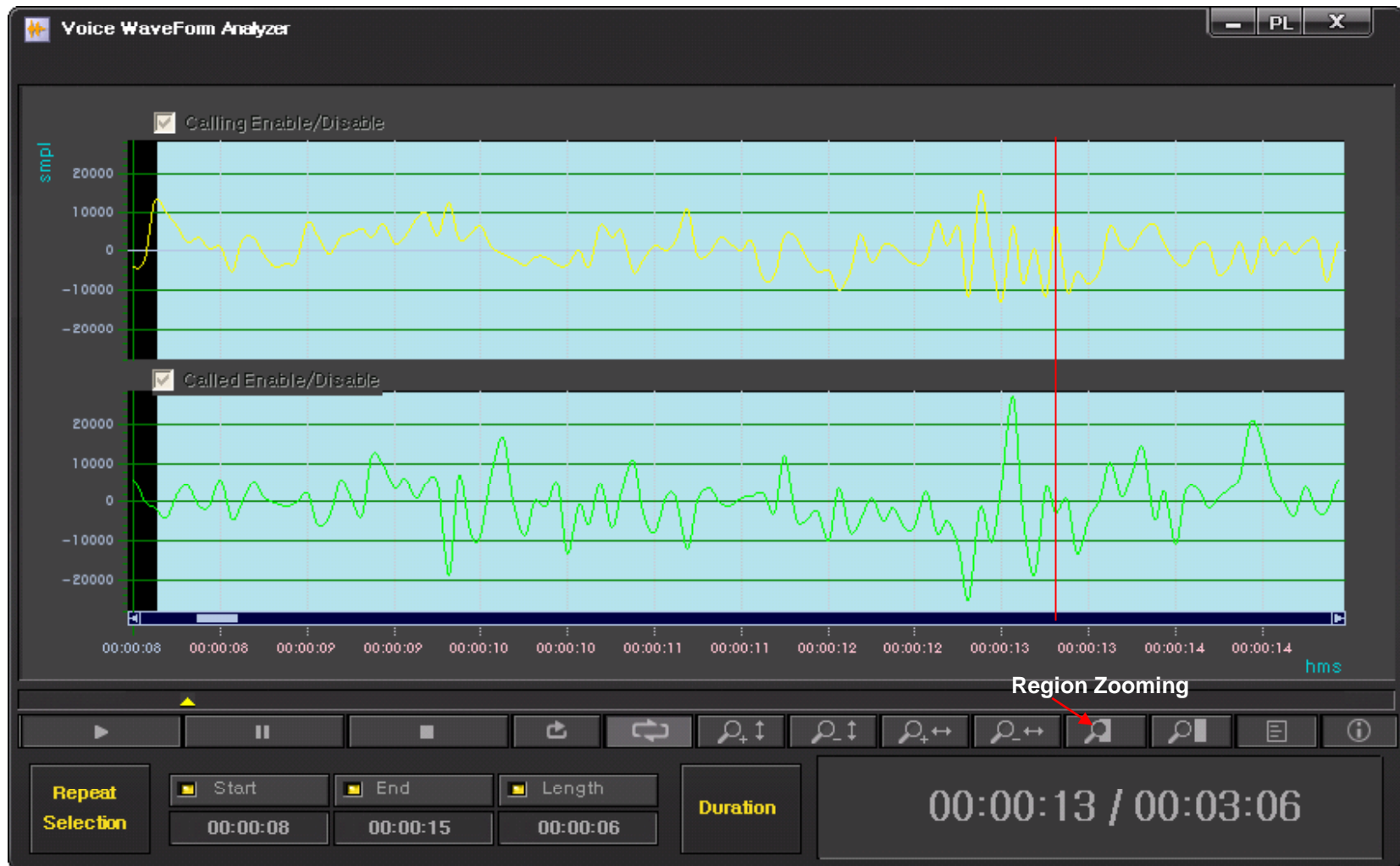

Recording File Waveform Analyzer

(Call Info. Display)

The screenshot displays the 'Voice WaveForm Analyzer' application window. The main interface features two waveform plots: a top plot with a yellow waveform and a bottom plot with a green waveform. A central 'Record Information' dialog box is open, displaying the following data:

Record Information	
Start Time	2007-06-12 10:11:28
End Time	2007-06-12 10:14:34
Record Duration	00:03:06
Record Memo	<input type="text"/>

Call Information	
Initiated Time	2007-06-12 10:13:15
Established Time	2007-06-12 10:13:16
Disconnected Time	2007-06-12 10:16:24
Call Duration	00:03:08

Calling Party	
Number	1015
User	
Codec	G711U
Directory	/mnt/hda1/callrecfiles
FileSize	1606k

Called Party	
Number	6015
User	
Codec	G711U
Directory	/mnt/hda1/callrecfiles
FileSize	1606k

At the bottom of the window, there is a control bar with playback buttons (play, pause, stop, etc.) and a 'Call Info. Display' button. Below the control bar, a 'Repeat Selection' section shows 'Start' (00:00:10), 'End' (00:00:11), and 'Length' (00:00:01). A 'Duration' section shows '00:00:11 / 00:03:06'. The text 'Original View Mode' is displayed above the duration. A red arrow points from the 'Call Info. Display' button to the 'Call Info. Display' text in the bottom right corner of the waveform area.

Live Call Recording List and Monitoring

The screenshot displays the Smart DVoiceR Manager interface. The main window is titled "Smart DVoiceR Manager" and features a menu bar (File, Advanced, Configuration, Help) and a toolbar. The central area is divided into "Current Call List Display" and "Live Play" sections. A "Record Session" window is open, showing a table of call records and a "Refresh Interval" set to 5 seconds. A "List Update Time" window is also visible, displaying call details for a specific call (ID 3006).

No.	Call ID	Source IP	Rec StartTime	Initiated Time	Established Time	Call Duration	Calling Num	Calling User	Calling SI...	Calling Trans...	C
1	46551	172.17.213.100	2007-06-13 15:20:42	2007-06-13 15:2...	2007-06-13 15:22:38	00:00:11	5009		2/1/0	G7231_63-> ...	2
2	46552	172.17.213.100	2007-06-13 15:20:42	2007-06-13 15:2...	2007-06-13 15:22:38	00:00:11	5007		1/3/0	G7231_63-> ...	2
3	46553	172.17.213.100	2007-06-13 15:20:43	2007-06-13 15:2...	2007-06-13 15:22:39	00:00:10	5013		3/1/0	G7231_63-> ...	2
4	46558	172.17.213.100	2007-06-13 15:20:44	2007-06-13 15:2...	2007-06-13 15:22:39	00:00:09	3015		7/3/0	G7231_63-> ...	5
5	46554	172.17.213.100	2007-06-13 15:20:44	2007-06-13 15:2...	2007-06-13 15:22:39	00:00:09	5011		2/3/0	G7231_63-> ...	2
6	46555	172.17.213.100	2007-06-13 15:20:44	2007-06-13 15:2...	2007-06-13 15:22:39	00:00:09	5014		3/2/0	G7231_63-> ...	2
7	46556	172.17.213.100	2007-06-13 15:20:44	2007-06-13 15:2...	2007-06-13 15:22:39	00:00:09	5011		3/3/0	G7231_63-> ...	2
8	46559	172.17.213.100	2007-06-13 15:20:45	2007-06-13 15:2...	2007-06-13 15:22:39	00:00:09	5011		7/2/0	G7231_63-> ...	5
9	46557	172.17.213.100	2007-06-13 15:20:45	2007-06-13 15:2...	2007-06-13 15:22:39	00:00:09	5011		0/3/0	G7231_63-> ...	2
10	46560	172.17.213.100	2007-06-13 15:20:46	2007-06-13 15:2...	2007-06-13 15:22:39	00:00:09	5011		7/0/0	G7231_63-> ...	5
11	46561	172.17.213.100	2007-06-13 15:20:47	2007-06-13 15:2...	2007-06-13 15:22:39	00:00:09	5011		1/0/0	G7231_63-> ...	2
12	46546	172.17.213.100	2007-06-13 15:20:34	2007-06-13 15:2...	2007-06-13 15:22:39	00:00:09	5011		4/3/0	G7231_63-> ...	5
13	46563	172.17.213.100	2007-06-13 15:20:47	2007-06-13 15:2...	2007-06-13 15:22:39	00:00:09	5011		6/0/0	G7231_63-> ...	5
14	46562	172.17.213.100	2007-06-13 15:20:50	2007-06-13 15:2...	2007-06-13 15:22:39	00:00:09	5011		1/2/0	G7231_63-> ...	2
15	46545	172.17.213.100	2007-06-13 15:20:36	2007-06-13 15:2...	2007-06-13 15:22:39	00:00:09	5011		3/0/0	G7231_63-> ...	2
16	46564	172.17.213.100	2007-06-13 15:20:50	2007-06-13 15:2...	2007-06-13 15:22:39	00:00:09	5011		4/0/0	G7231_63-> ...	5
17	46565	172.17.213.100	2007-06-13 15:20:51	2007-06-13 15:2...	2007-06-13 15:22:39	00:00:09	5011		5/3/0	G7231_63-> ...	5
18	46547	172.17.213.100	2007-06-13 15:20:41	2007-06-13 15:2...	2007-06-13 15:22:39	00:00:09	5011		0/2/0	G7231_63-> ...	2
19	46566	172.17.213.100	2007-06-13 15:20:52	2007-06-13 15:2...	2007-06-13 15:22:39	00:00:09	5011		6/2/0	G7231_63-> ...	5
20	46548	172.17.213.100	2007-06-13 15:20:41	2007-06-13 15:2...	2007-06-13 15:22:39	00:00:09	5011		1/1/0	G7231_63-> ...	2
21	46567	172.17.213.100	2007-06-13 15:20:52	2007-06-13 15:2...	2007-06-13 15:22:39	00:00:09	5011		4/2/0	G7231_63-> ...	5
22	46549	172.17.213.100	2007-06-13 15:20:41	2007-06-13 15:2...	2007-06-13 15:22:39	00:00:09	5011		2/0/0	G7231_63-> ...	2
23	46568	172.17.213.100	2007-06-13 15:20:52	2007-06-13 15:2...	2007-06-13 15:22:39	00:00:09	5011		5/2/0	G7231_63-> ...	5
24	46569	172.17.213.100	2007-06-13 15:20:52	2007-06-13 15:2...	2007-06-13 15:22:39	00:00:09	5011		6/1/0	G7231_63-> ...	5
25	46570	172.17.213.100	2007-06-13 15:20:52	2007-06-13 15:2...	2007-06-13 15:22:39	00:00:09	5011		5/0/0	G7231_63-> ...	5
26	46550	172.17.213.100	2007-06-13 15:20:42	2007-06-13 15:2...	2007-06-13 15:22:39	00:00:09	5011		0/0/0	G7231_63-> ...	2
27	46573	172.17.213.100	2007-06-13 15:20:53	2007-06-13 15:2...	2007-06-13 15:22:39	00:00:09	5011		4/1/0	G7231_63-> ...	5
28	6208	172.16.9.60	2007-06-13 15:20:30	2007-06-13 15:2...	2007-06-13 15:22:39	00:00:09	5011		4/2/0	G729A_8->G...	2
29	6209	172.16.9.60	2007-06-13 15:20:30	2007-06-13 15:2...	2007-06-13 15:22:39	00:00:09	5011		5/0/0	G729A_8->G...	2
30	6223	172.16.9.60	2007-06-13 15:20:45	2007-06-13 15:2...	2007-06-13 15:22:39	00:00:09	5011		1/3/0	G729A_8->G...	6
31	6213	172.16.9.60	2007-06-13 15:20:32	2007-06-13 15:2...	2007-06-13 15:22:39	00:00:09	5011		4/0/0	G729A_8->G...	2
32	6214	172.16.9.60	2007-06-13 15:20:32	2007-06-13 15:2...	2007-06-13 15:22:39	00:00:09	5011		4/3/0	G729A_8->G...	2
33	6215	172.16.9.60	2007-06-13 15:20:32	2007-06-13 15:2...	2007-06-13 15:22:39	00:00:09	5011		4/1/0	G729A_8->G...	2
34	6224	172.16.9.60	2007-06-13 15:20:49	2007-06-13 15:2...	2007-06-13 15:22:42	00:00:04	1006		1/2/0	G729A_8->G...	6
35	5882	172.16.9.60	2007-06-13 15:08:56	2007-06-13 15:1...	2007-06-13 15:10:48	00:11:57	1015		3/3/0	G729A_8->G...	6
36	6220	172.16.9.60	2007-06-13 15:20:41	2007-06-13 15:2...	2007-06-13 15:22:35	00:00:12	1004		1/0/0	G729A_8->G...	6
37	6221	172.16.9.60	2007-06-13 15:20:42	2007-06-13 15:2...	2007-06-13 15:22:35	00:00:11	1005		1/1/0	G729A_8->G...	6

The "AddPac" live monitoring window shows the following details:

- Record Information:** Start Time: 2007-06-15 14:16:46
- Call Information:** Initiated Time: 2007-06-15 14:18:56, Established Time: 2007-06-15 14:18:57
- Calling Party:** DialNumber: 3006, User: G711U, Codec: G711U, Directory: /mnt/hda1/callrecfiles, FileSize: 4/0/0
- Called Party:** DialNumber: 5022, User: G711U, Codec: G711U, Directory: /mnt/hda1/callrecfiles, FileSize: 4/0/0

Event Management (Configuration)

Smart DVoiceR Manager

File Advanced Configuration Help

Smart DVoiceR Manager AddPac Technology

Smart DVoiceR Manager

- Smart DVoiceR Manager
 - User Management
 - Users
 - Device Management
 - Smart Recording Server
 - Smart Recording Terminal
 - Recording Management
 - Record Search
 - Record Session
 - Event & Monitoring
 - Event Configuration**
 - Event Monitoring
 - System Monitoring
 - Event History
 - Recording Board
 - Board Users
 - Board Groups
 - Map List

Event level Configuration

Sound Play On/Off at Server Emergency Event Occurring

Server IP address

Event Port Number

Realtime event level Setting

Event logging level Setting

Event Source

Host : 172.16.4.22

Listen Port : 514

1. Emergency
The presence of a condition that has either caused the system to become unstable or has crashed the system.

2. Error
Error events are warnings of conditions that will affect the performance of the MX.

Event Filter | Event Logging Filter

+ Event filter setting for source.

Select / Deselect All

Category	Severity	Description
<input checked="" type="checkbox"/> recording	Warning	recording
<input checked="" type="checkbox"/> play	Warning	play
<input checked="" type="checkbox"/> system	Warning	system

Use Emergency Sound

OK Cancel

Event Source

Host : 172.16.4.22

Listen Port : 514

1. Emergency
The presence of a condition that has either caused the system to become unstable or has crashed the system.

2. Error
Error events are warnings of conditions that will affect the performance of the MX.

Event Filter | Event Logging Filter

+ Event filter setting for logging.

Select / Deselect All

Category	Severity	Description
<input checked="" type="checkbox"/> recording	Warning	recording
<input checked="" type="checkbox"/> play	Warning	play
<input checked="" type="checkbox"/> system	Warning	system

Use Emergency Sound

OK Cancel

2007-06-14 오후 4:25:35 Ver. 1.0.2720 172.16.4.22:9200 root

Event Management (Monitoring)

The screenshot displays the Smart DVoiceR Manager interface. The main window shows a list of call records with columns for No., Call ID, Source IP, Rec StartTime, Initiated Time, Established Time, Call Duration, Calling Num, and Calli... The interface includes a menu bar (File, Advanced, Configuration, Help), a toolbar, and a left-hand navigation tree. A 'Refresh Interval' of 5 seconds is set. Red arrows point to specific features: 'Event Display Window' points to the left navigation tree; 'Event level Configuration Window' points to the 'Record Session' option; 'Event Display Window Clear' points to the trash icon in the event monitoring window; and 'Event Receiving Pause' points to the 'Pause' button in the event monitoring window.

No.	Call ID	Source IP	Rec StartTime	Initiated Time	Established Time	Call Duration	Calling Num	Calli...
1	690	172.17.213.100	2007-06-14 16:25:24	2007-06-14 16:27:25	2007-06-14 16:27:29	00:00:20	5012	
2	693	172.17.213.100	2007-06-14 16:25:24	2007-06-14 16:27:28	2007-06-14 16:27:29	00:00:20	5005	
3	694	172.17.213.100	2007-06-14 16:25:25	2007-06-14 16:27:29	2007-06-14 16:27:30	00:00:19	5001	
4	695	172.17.213.100	2007-06-14 16:25:26	2007-06-14 16:27:29	2007-06-14 16:27:31	00:00:18	5006	
5	696	172.17.213.100	2007-06-14 16:25:26	2007-06-14 16:27:30	2007-06-14 16:27:31	00:00:18	5007	
6	697	172.17.213.100	2007-06-14 16:25:27	2007-06-14 16:27:31	2007-06-14 16:27:32	00:00:17	5008	
7	698	172.17.213.100	2007-06-14 16:25:28	2007-06-14 16:27:32	2007-06-14 16:27:33	00:00:16	5009	
8	699	172.17.213.100	2007-06-14 16:25:30	2007-06-14 16:27:34	2007-06-14 16:27:35	00:00:14	5011	
9	700	172.17.213.100	2007-06-14 16:25:31	2007-06-14 16:27:34	2007-06-14 16:27:36	00:00:13	5010	
10	701	172.17.213.100	2007-06-14 16:25:32	2007-06-14 16:27:36	2007-06-14 16:27:37	00:00:12	5013	
11	702	172.17.213.100	2007-06-14 16:25:34	2007-06-14 16:27:37	2007-06-14 16:27:38	00:00:10	5014	
12	703	172.17.213.100	2007-06-14 16:25:38	2007-06-14 16:27:42	2007-06-14 16:27:43	00:00:06	5015	
13	704	172.17.213.100	2007-06-14 16:25:39	2007-06-14 16:27:43	2007-06-14 16:27:44	00:00:05	3000	
14	705	172.17.213.100	2007-06-14 16:25:40	2007-06-14 16:27:44	2007-06-14 16:27:45	00:00:04	3001	
15	706	172.17.213.100	2007-06-14 16:25:42	2007-06-14 16:27:45	2007-06-14 16:27:46	00:00:02	3002	
16	684	172.17.213.100	2007-06-14 16:25:17	2007-06-14 16:27:20	2007-06-14 16:27:21	00:00:27	3012	
17	707	172.17.213.100	2007-06-14 16:25:43	2007-06-14 16:27:46	2007-06-14 16:27:47	00:00:01	3003	
18	686	172.17.213.100	2007-06-14 16:25:18	2007-06-14 16:27:21	2007-06-14 16:27:22	00:00:26	3013	
19	708	172.17.213.100	2007-06-14 16:25:44	2007-06-14 16:27:47	2007-06-14 16:27:49	00:00:00	3004	
20	687	172.17.213.100	2007-06-14 16:25:18	2007-06-14 16:27:22	2007-06-14 16:27:23	00:00:26	3014	
21	685	172.17.213.100	2007-06-14 16:25:19	2007-06-14 16:27:23	2007-06-14 16:27:24	00:00:25	5000	
22	689	172.17.213.100	2007-06-14 16:25:20	2007-06-14 16:27:23	2007-06-14 16:27:24	00:00:24	3015	

Event Monitoring window details:

DateTime	Host	Severity	Module	Description
Jun 14 07:25:43	172.16.4.22	Informational	recording	recording stopping ; call_id = 682, ip = 172.17.213.100, mac_addr = 0002,a403,cc82
Jun 14 07:25:43	172.16.4.22	Informational	recording	Stop Recording, bind id:2003
Jun 14 07:25:43	172.16.4.22	Informational	recording	new recording starting ; call_id = 707, ip = 172.17.213.100, mac_addr = 0002,a403,cc82
Jun 14 07:25:43	172.16.4.22	Informational	recording	Start Recording, bind id:2003
Jun 14 07:25:44	172.16.4.22	Informational	recording	recording stopping ; call_id = 683, ip = 172.17.213.100, mac_addr = 0002,a403,cc82
Jun 14 07:25:44	172.16.4.22	Informational	recording	Stop Recording, bind id:2003
Jun 14 07:25:44	172.16.4.22	Informational	recording	new recording starting ; call_id = 708, ip = 172.17.213.100, mac_addr = 0002,a403,cc82
Jun 14 07:25:44	172.16.4.22	Informational	recording	Start Recording, bind id:2003
Jun 14 07:25:44	172.16.4.22	Debug	system	get current recording session ;
Jun 14 07:25:44	172.16.4.22	Informational	recording	new recording starting ; call_id = 709, ip = 172.17.213.100, mac_addr = 0002,a403,cc82
Jun 14 07:25:44	172.16.4.22	Informational	recording	Start Recording, bind id:2003
Jun 14 07:25:45	172.16.4.22	Informational	recording	recording stopping ; call_id = 684, ip = 172.17.213.100, mac_addr = 0002,a403,cc82
Jun 14 07:25:45	172.16.4.22	Informational	recording	Stop Recording, bind id:2003
Jun 14 07:25:45	172.16.4.22	Informational	recording	new recording starting ; call_id = 710, ip = 172.17.213.100, mac_addr = 0002,a403,cc82
Jun 14 07:25:45	172.16.4.22	Informational	recording	Start Recording, bind id:2003
Jun 14 07:25:46	172.16.4.22	Informational	recording	recording stopping ; call_id = 686, ip = 172.17.213.100, mac_addr = 0002,a403,cc82
Jun 14 07:25:46	172.16.4.22	Informational	recording	Stop Recording, bind id:2003
Jun 14 07:25:46	172.16.4.22	Debug	system	get current recording session ;

Event Management

(System Monitoring)

The screenshot displays the 'System Monitoring' window of the Smart DVoiceR Manager. The interface includes a navigation tree on the left and a main performance dashboard. The dashboard features several charts and data tables:

- CPU Usage:** A gauge chart showing 40% usage.
- CPU Usage History:** A line graph showing fluctuating CPU usage over time.
- Memory Usage:** A gauge chart showing 61 MB usage.
- Memory Usage History:** A line graph showing memory usage over time.
- Trans Codec Usage:** A gauge chart showing a maximum of 128 and a current value of 54.
- Trans Codec Usage History:** A line graph showing trans codec usage over time.
- Storage Usage:** Two progress bars for rootfs (/) and /dev/hda1 (/mnt/hda1).

CPU	
Total(%)	100
Used(%)	0

Memory	
Total	254752 KB
Available	171860 KB
Used	82892 KB
Used(%)	32,54

Transcoding Channel	
Max	128
Used	0

HDD	
Total	304273 MB
Available	138124 MB
Used	166149 MB
Used(%)	54,61

Storage Usage Summary:

- rootfs (/): 2.00 GB used, 3.00 GB total
- /dev/hda1 (/mnt/hda1): 139.00 GB used, 300.00 GB total

System Information: 2007-06-14 오후 4:38:08, Ver. 1,0,2720, 172, 16, 4, 22:9200, root

Event Management

(Event History)

Event Search Time Setting

Start : 2007-06-14 00:00:00
End : 2007-06-14 23:59:59

Event category

Recording : Debug
 Play : Debug
 System : Debug

Search Condition Setting

Filter Name : Event
Rule : IsExactly
Search :

Event History Table

No.	Event Time	Host	Category	Severity	Event
22	2007-06-14 15:14:21	172.16.4.22	recording	Informational	recording stopping : call_id = 0, ip = , mac_addr =
23	2007-06-14 15:14:21	172.16.4.22	recording	Informational	recording stopping : call_id = 0, ip = , mac_addr =
24	2007-06-14 15:15:01	172.16.4.22	recording	Informational	new recording starting : call_id = 9702, ip = 172.16.9...
25	2007-06-14 15:15:32	172.16.4.22	recording	Informational	new recording starting : call_id = 9784, ip = 172.16.9...
26	2007-06-14 15:15:32	172.16.4.22	recording	Informational	new recording starting : call_id = 9788, ip = 172.16.9...
27	2007-06-14 15:15:33	172.16.4.22	recording	Informational	new recording starting : call_id = 9790, ip = 172.16.9...
28	2007-06-14 15:15:35	172.16.4.22	recording	Informational	new recording starting : call_id = 9792, ip = 172.16.9...
29	2007-06-14 15:15:37	172.16.4.22	recording	Informational	new recording starting : call_id = 9794, ip = 172.16.9...
30	2007-06-14 15:15:39	172.16.4.22	recording	Informational	new recording starting : call_id = 9797, ip = 172.16.9...
31	2007-06-14 15:15:40	172.16.1.48	system	Debug	getChannelUsage : client ip = 172.16.1.48, port = 1824
32	2007-06-14 15:15:43	172.16.1.48	system	Debug	get system information requested : cpu = 15%, mem...
33	2007-06-14 15:15:44	172.16.1.48	system	Debug	get system information requested : cpu = 20%, mem...
34	2007-06-14 15:15:45	172.16.1.48	system	Debug	get system information requested : cpu = 20%, mem...
35	2007-06-14 15:15:45	172.16.1.48	system	Debug	get transcoding channel usage :
36	2007-06-14 15:15:46	172.16.1.48	system	Debug	getChannelUsage : client ip = 172.16.1.48, port = 1824
37	2007-06-14 15:15:47	172.16.1.48	system	Debug	get system information requested : cpu = 1%, memor...
38	2007-06-14 15:15:47	172.16.1.48	system	Debug	get transcoding channel usage :
39	2007-06-14 15:15:48	172.16.1.48	system	Debug	getChannelUsage : client ip = 172.16.1.48, port = 1824
40	2007-06-14 15:15:49	172.16.1.48	system	Debug	getChannelUsage : client ip = 172.16.1.48, port = 1824
41	2007-06-14 15:15:50	172.16.1.48	system	Debug	getChannelUsage : client ip = 172.16.1.48, port = 1824
42	2007-06-14 15:15:51	172.16.1.48	system	Debug	get system information requested : cpu = 16%, mem...
43	2007-06-14 15:15:51	172.16.1.48	system	Debug	get transcoding channel usage :
44	2007-06-14 15:15:52	172.16.1.48	system	Debug	getChannelUsage : client ip = 172.16.1.48, port = 1824
45	2007-06-14 15:15:53	172.16.1.48	system	Debug	getChannelUsage : client ip = 172.16.1.48, port = 1824
46	2007-06-14 15:15:54	172.16.1.48	system	Debug	getChannelUsage : client ip = 172.16.1.48, port = 1824
47	2007-06-14 15:15:55	172.16.1.48	system	Debug	getChannelUsage : client ip = 172.16.1.48, port = 1824
48	2007-06-14 15:15:56	172.16.1.48	system	Debug	getChannelUsage : client ip = 172.16.1.48, port = 1824
49	2007-06-14 15:15:57	172.16.1.48	system	Debug	get system information requested : cpu = 16%, mem...
50	2007-06-14 15:15:57	172.16.1.48	system	Debug	get transcoding channel usage :
51	2007-06-14 15:15:58	172.16.4.22	recording	Informational	recording stopping : call_id = 9785, ip = 172.16.9.60, ...
52	2007-06-14 15:15:58	172.16.1.48	system	Debug	get system information requested : cpu = 8%, memor...
53	2007-06-14 15:15:58	172.16.1.48	system	Debug	get transcoding channel usage :



Thank you!

AddPac Technology Co., Ltd.
Sales and Marketing

Phone +82.2.568.3848 (KOREA)

FAX +82.2.568.3847 (KOREA)

E-mail : sales@addpac.com