

AP-VWP80

IP Video Wall PAD

High Performance IP Video Wall PAD Solution

Preliminary Product Overview

(Without notice, following described technical spec. can be changed)



AddPac

AddPac Technology

Sales and Marketing

www.addpac.com

Contents

- Product Overview
- Product Highlights
- Hardware Specification
- Software Service
- Video Service & Features
- Audio & Voice Service and Features
- OSD Software Features
- Smart Web Manager
- Application Area
- Ordering Information

Product Overview

AP-VWP80 IP Video Wall PAD

- High Performance IP Video Wall PAD Solution
- TFT Color LCD, Touch Screen, Touch Sensor, Internal MIC & Speaker
- High Quality “7 Inch LCD, 800x480 Video Resolution
- SIP VoIP Signaling Stack Embedded (Optional H.323)
- High-performance Video/Voice Codec Support
 - H.264/MPEG4/H.263, G.711, etc
- One(1) 10/100Mbps Fast Ethernet
- High Quality Speaker Phone Features
- PSTN with CID Interface Support (Option)
- Power Acoustic Echo Canceller (Option)
- PoE(Power over Ethernet) or Internal SMPS Power Support (Option)
- Video Camera Sensor (Option)
- Powerful Network Protocols (PPPoE, DHCP, Static Routing, etc)
- Interworking with Smart Hub for Sensor Devices
- Firmware Upgradeable Architecture
- Advanced Voice QoS Mechanism

Product Highlights

AP-VWP80 IP Video Wall PAD

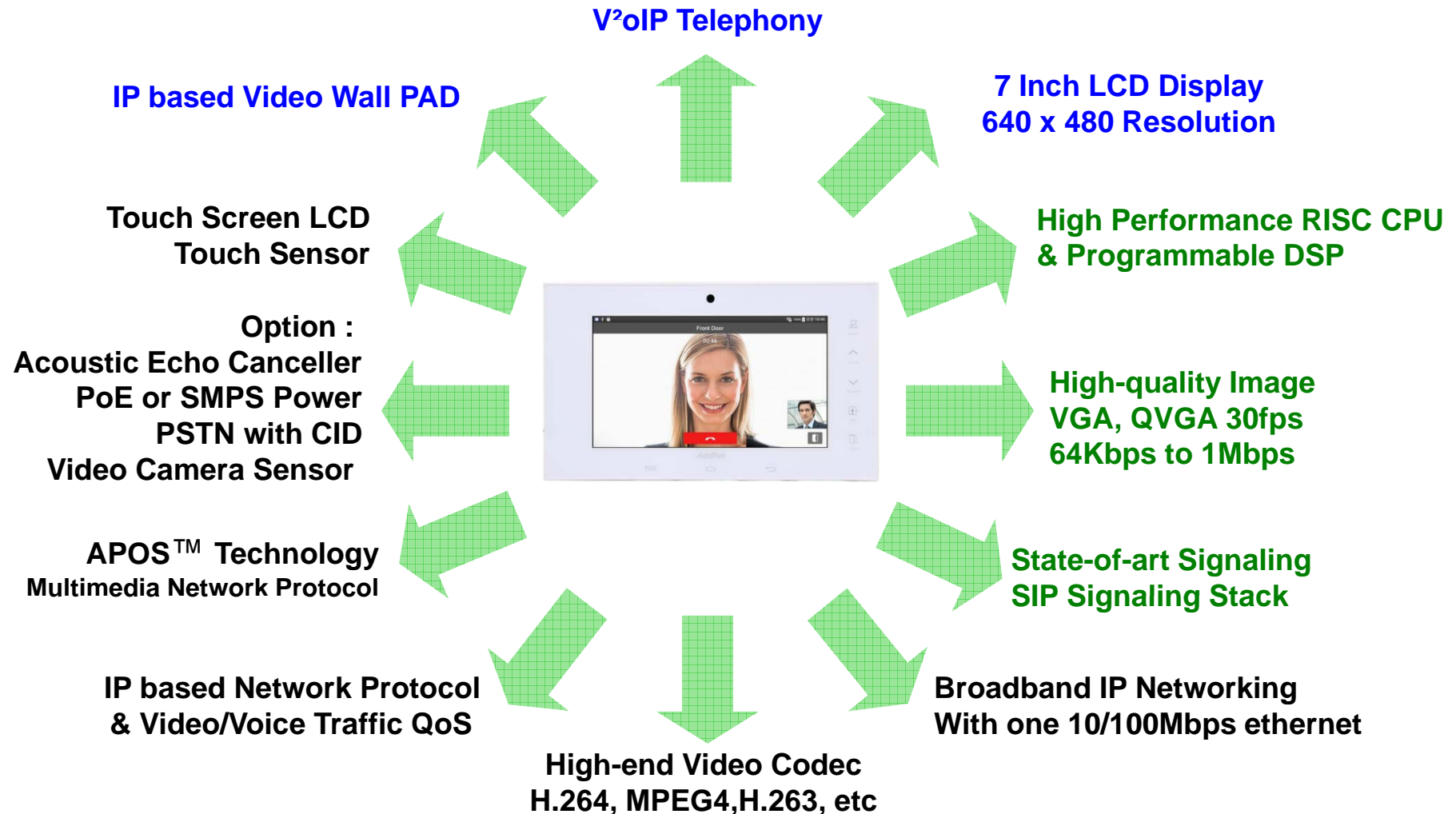

Multimedia Service

AP-VWP80 IP Video Wall PAD

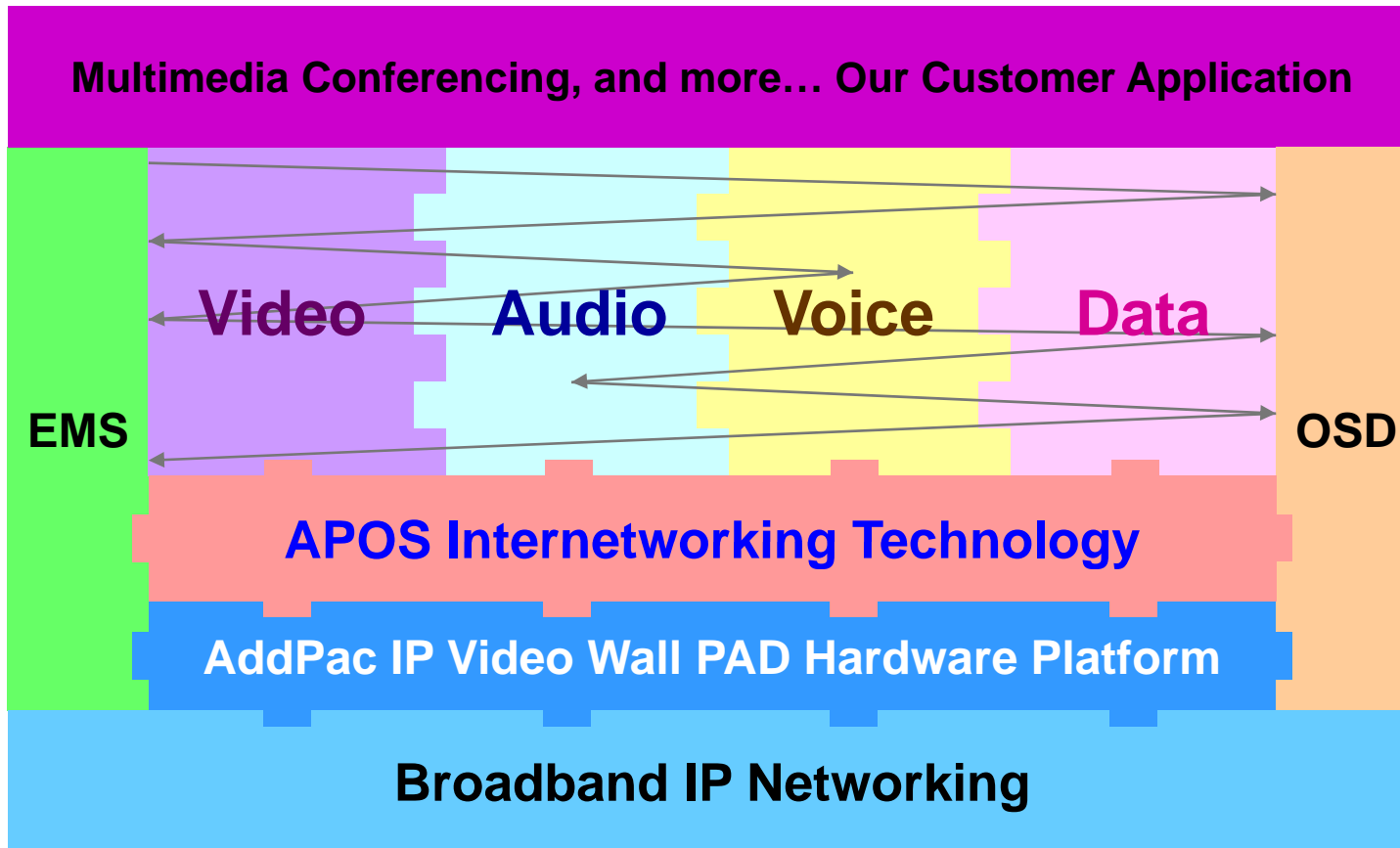

- APOS : AddPac Internetworking Operating System
- OSD : On- Screen Display
- EMS : Element Management System

Hardware Specification

AP-VWP80 IP Video Wall PAD

RISC
CPU

High-end
DSP

- RISC+DSP Microprocessor Computing Power
- Audio and Voice Interface
 - Internal MIC
 - Internal Speaker
- Video Camera Interface (Option)
- TFT Color LCD Interface with Touch Screen
 - 7 Inch LCD, 800 x 480, D1 Video Resolution
- Network Interface
 - One(1) 10/100Mbps Fast Ethernet
- PSTN Interface with CID (Caller ID Detection)
- Powerful Acoustic Echo Canceller (Option)
 - Half Duplex (Default)
 - Full Duplex, Powerful Acoustic Echo Canceller (Option)
- Wall Mount
- Power Supply
 - Power over Ethernet (Option)
 - Internal SMPS Power (Default)

Hardware Specification

AP-VWP80 IP Video Wall PAD

RISC
CPU

High-end
DSP

- **Acoustic Echo Canceller (Option)**
 - Full-duplex operation during double-talk situations
 - One channel AEC, one channel LEC up to 256ms shared
 - Cancels echoes with up to 10dB echo return
 - Advanced noise reduction(up to 20dB)
- **Speaker**
 - Impedance : 8 +/-15%ohm at 1kHz, 1.0 Vrms
 - Sound Pressure : 90 +/- 3dB at 0.1W/10 CM
at 800Hz, 1.0kHz, 1.2kHz, 1.5kHz
 - Resonance Level : 550Hz +/- 20%Hz at Fo Hz, 1.0Vrms
 - Frequency Range : Fo Hz ~20kHz
 - Input Power : Normal : 1.0 W, Max : 2.0W
- **Audio Amplifier**
 - 1-W BTL Output(5V, 0.11 % THD+N)
 - Uncompensated Gains of 2 to 20 (BTL Mode)
 - Thermal and Shot-circuit Protection
 - High Supply Ripple Rejection Ratio
- **PoE(Power over Ethernet), Option**
 - IEEE802.3af compliant
 - Input voltage range 36V to 57V
 - Short-circuit Protection

Hardware Specification

AP-VWP80 IP Video Wall PAD

RISC
CPU

High-end
DSP

- **LCD Controller**
 - One-Chip Solution for amorphous TFT-LCD
 - Support resolution up to 480xRGBx640
 - Built-in 172800 bytes internal RAM
 - 6,8,16, and 18-bit RGB Interface
 - Resize Function (x ½, x ¼)
 - On-Chip Power Management System
- **Video Camera (Option)**
 - High Sensitivity for low-light operation
 - Output support for Raw RGB, RGB, and YCrCb format
 - Image Size : VGA, QVGA, and any size scaling down from CIF to 40x30
 - Support AEC, AGC,AWB, ABF, ABLC
 - Saturation Level, Edge Enhancement Level, De-noise level Auto adjust

Hardware Specification

AP-VWP80 IP Video Wall PAD

RISC
CPU

High-end
DSP

Front Side

Video Camera

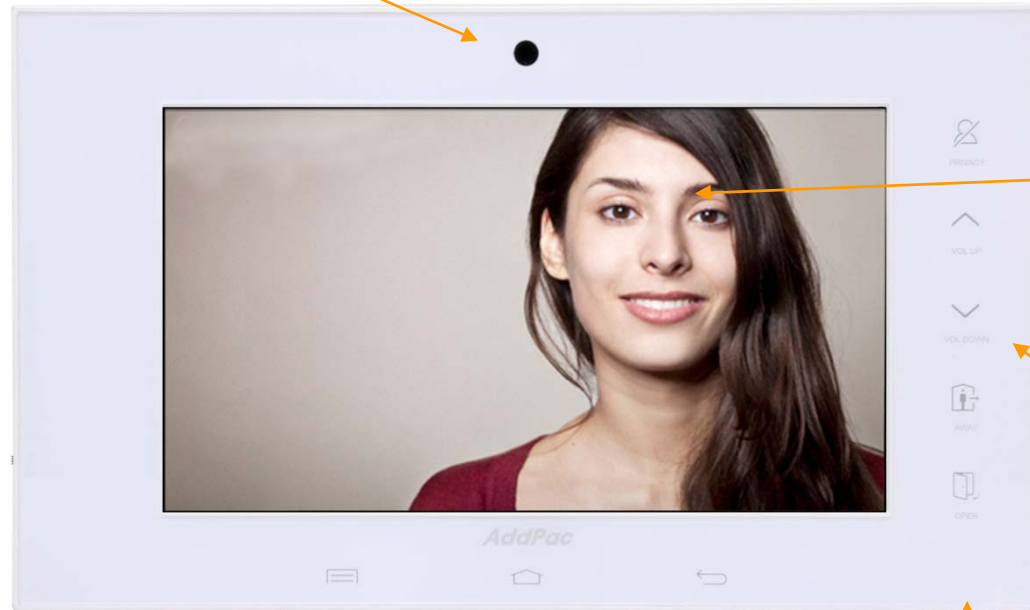

TFT LCD Display
with Touch
Screen

Touch Sensor
Key

Internal MIC Input

Hardware Specification

AP-VWP80 IP Video Wall PAD

RISC
CPU

High-end
DSP

Back Side

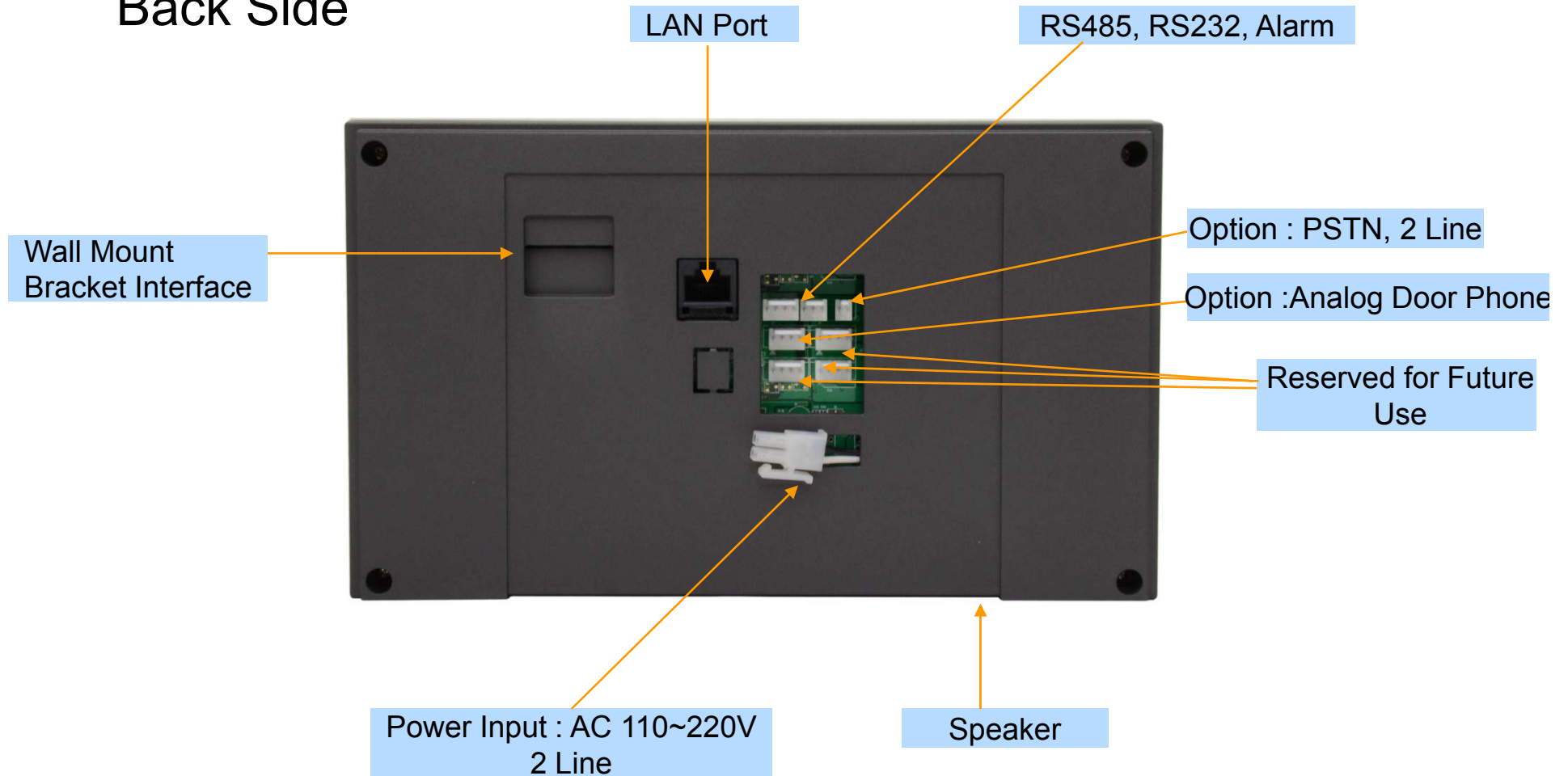

Hardware Specification

AP-VWP80 IP Video Wall PAD

RISC
CPU

High-end
DSP

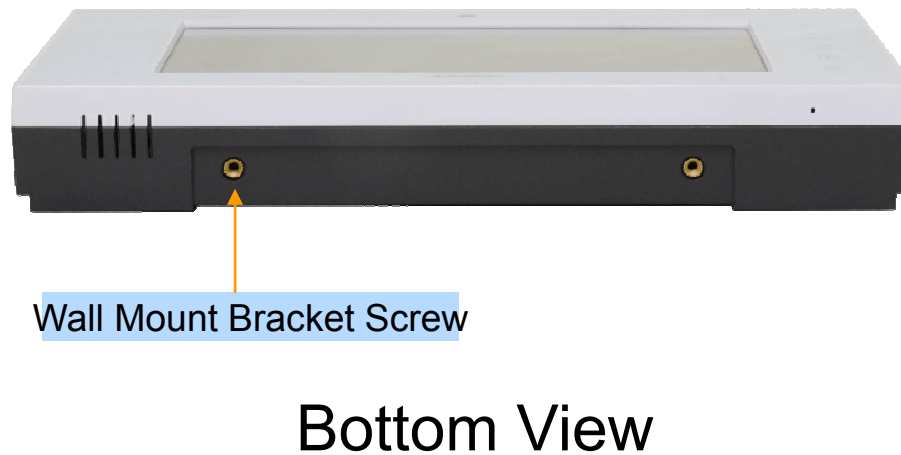
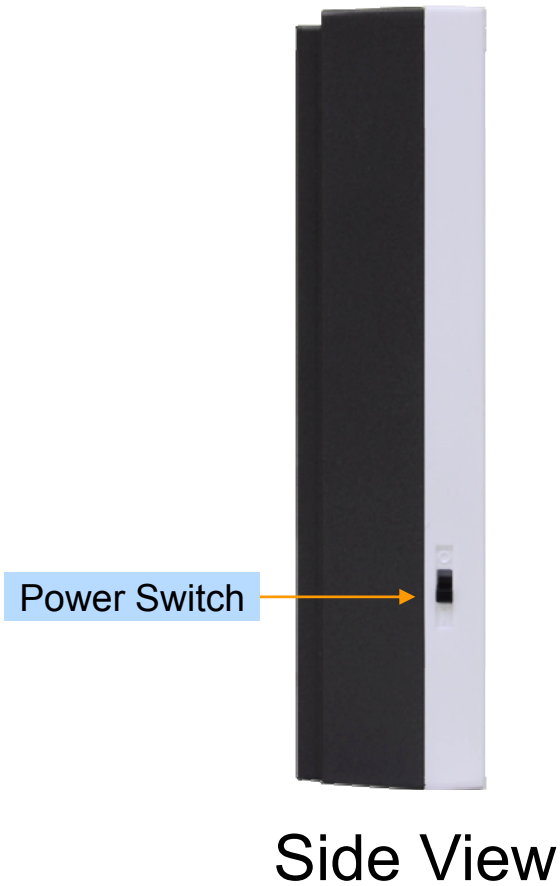

Software Service

AP-VWP80 IP Video Wall PAD

- Built-in AddPac APOS Internetworking Software
 - Scalability, Functionality, and Stability Features
 - Video Traffic QoS Control
- Programmable Video, Audio, and Voice Services
 - Video Codes, Audio, and Voice Codec
- Firmware Upgradeable DSP Architecture
- OSD (On-screen Display) Function Support
- Industry Standard IP based Network Protocol Features

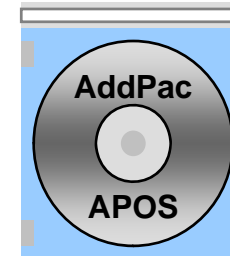

Video Service and Features

AP-VWP80 IP Video Wall PAD

- High-performance Video Codec Support
 - H.264, MPEG4, H.263, etc
- Image Resolution Support
 - Remote Display : VGA, QVGA, etc
 - Video Encoding : VGA(640x480), QVGA(320x240)
- Up to 30fps with VGA Resolution
- 128Kbps to 1Mbps Operating Video Traffic Bandwidth
- Rate Control for Video Traffic QoS
 - Ensuring Optimized Quality
 - Frame Rate with Limited Bandwidth
- High-end Error Resilient Against Various Packet Error

Audio & Voice Service and Features

AP-VWP80 IP Video Wall PAD

- Audio & Voice Networking Interface
 - Audio Mic-In Interface
 - Speaker Out Interface
 - PSTN Interface with CID
- VoIP based Signaling Protocol Support
 - SIP Signaling Protocol Stack
- High-performance Audio & Voice Codec Support
 - G.711, G.726 Audio Codec
- Enhanced QoS Management Features for Voice Traffics



Smart Web Manager (Example)

Smart Web Manager

AP-VWP80 IP Video Wall PAD

- Main Screen
- System
 - Language
 - LAN Setup
 - DACS
 - Display
 - File Browser
- SIP Call & Media
 - SIP (Session Initiation Protocol)
 - Speed Dial
 - Media
- Miscellaneous
 - Door Control and Test
 - Network Test

Smart Web Manager : Main Screen

AP-VWP80 IP Video Wall PAD

The screenshot displays the Smart Web Manager interface. At the top, there is a header with the logo and URL 'www.addpac.com'. Below the header, there are four icons: a gear (Initialization), a power button (Rebooting), a floppy disk (Save), and a terminal (Telnet). The main content area is divided into three sections:

- Menu Tree:** A sidebar on the left with three expandable sections: 'System' (Language, LAN Setup, DACS, Display Manager, File Browser), 'Call & Media' (Server SIP, Speed Dial, Media), and 'Miscellaneous' (Ping, Door Open).
- Configure Language:** The central panel shows a configuration form with two radio buttons: '한국어' (unselected) and 'English' (selected). Below the form is an 'Apply' button with a green checkmark.
- System Information and Help Message:** The right panel contains two sections: 'Information' with details like 'AddPac Technology', 'Model : VAC50_G2', 'DACS : (0)', 'DACS Registration : Fail', and 'SIP : 172.17.250.250(5060)'; and 'Description' with the text 'Choose the basic language to be applied. English is set at default.'

Menu Tree

Output Screen after
Menu Select

System Information and
Help Message

Smart Web Manager : SIP configuration

AP-VWP80 IP Video Wall PAD

SIP (Session Initiation Protocol)

SIP server check if exist.

Use SIP Server

Yes No

SIP Basic Information Display

Primary SIP Server

172.17.250.250

5060

Server address and Port (default 5060)

Secondary SIP Server

5060

Server address and Port (default 5060)

Local Domain Name

(SIP userpart of authentication)

SIP Signaling Port

5060

(default 5060, between 1 to 65535)

Register Expiration

60

(in seconds, default 60, between 10 to 86400)

Session Re-Fresh

INVITE UPDATE

Session Expire Time

1800

(in seconds, default 1800, between 30 to 86400, 0 = disable)

Min-SE

1800

(in seconds, default 1800, between 30 to 86400)

Extension

1020

Number, Password

Extension

Telephone Line Number and Password Configuration Same Information is used when DACS is connected

AddPac

AP-VWP80 IP Video Wall PAD

Application Area

- Point-to-Point Application (Simple Application)
- Point-to-Multipoint Application
 - All AddPac Solution
(Call Manager + Door Access Control Server)
 - Legacy PBX Environment
 - Legacy IP-PBX Environment
- Smart Home Application



Point-to-Point Connection (Simple Appl.)

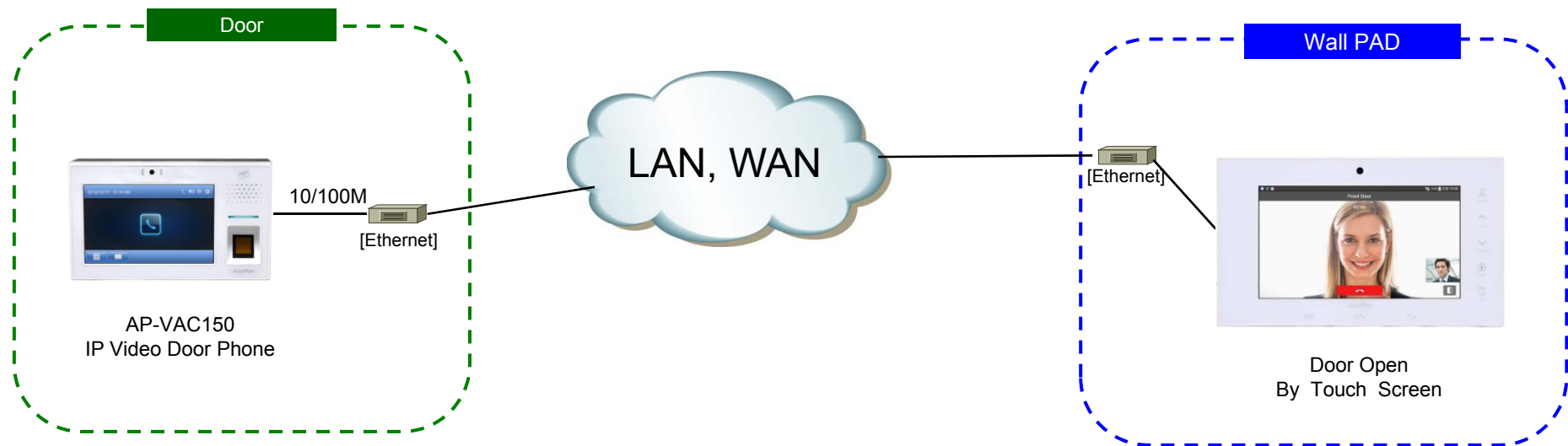

Integrated Door Access Control and Call Control (All AddPac Solution)

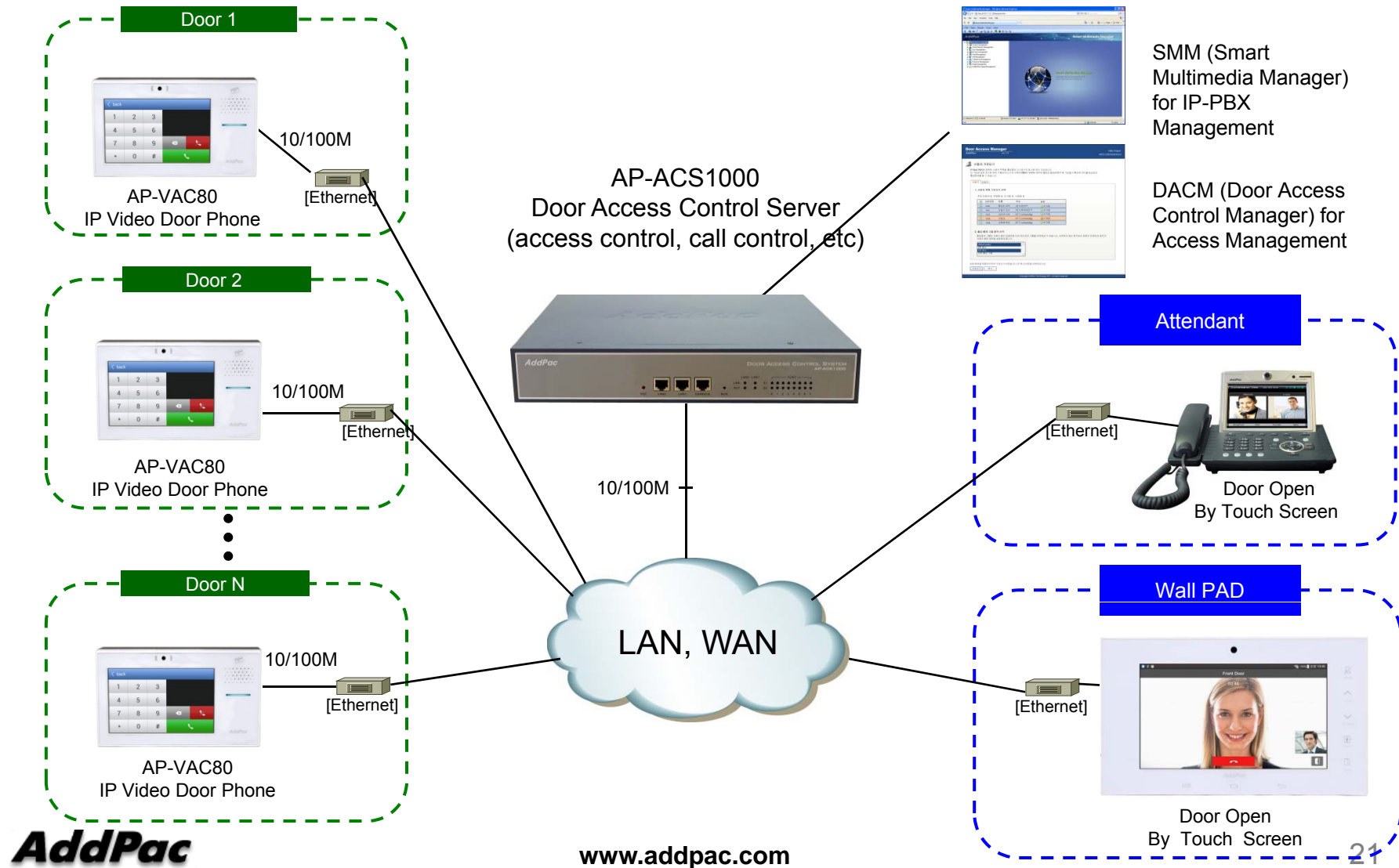

Legacy PBX Environment

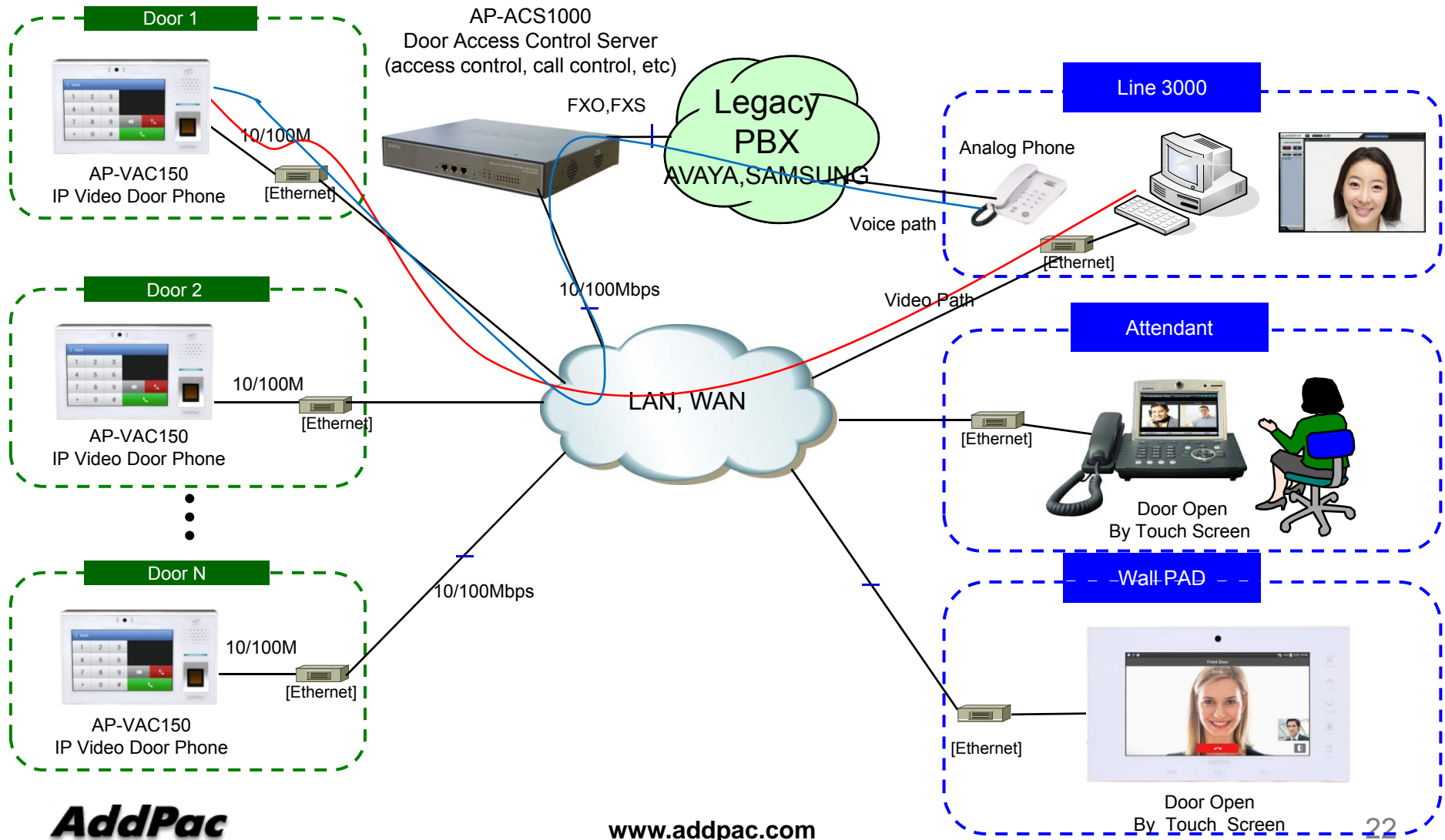

Legacy IP-PBX Environment

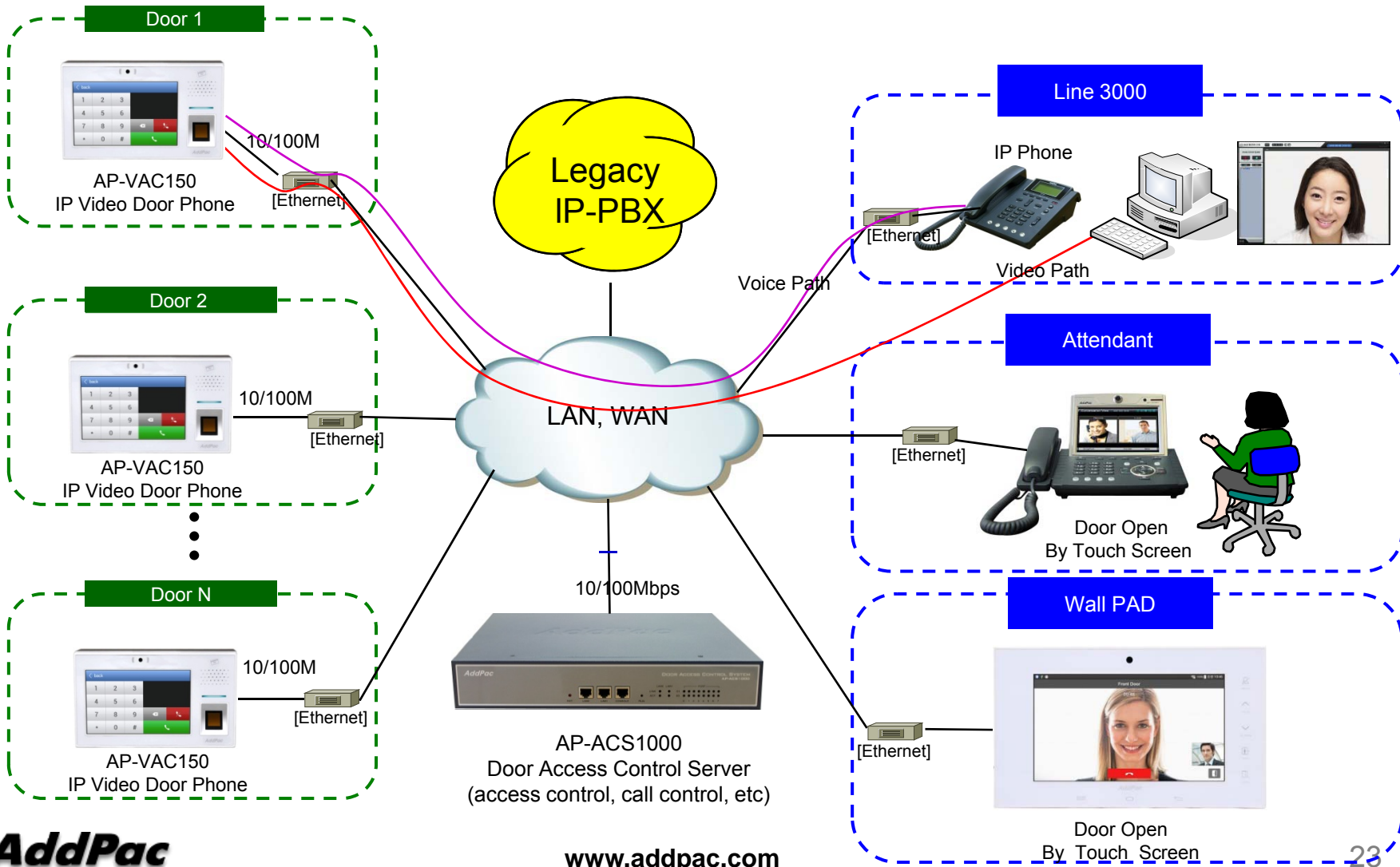

Smart Home Application

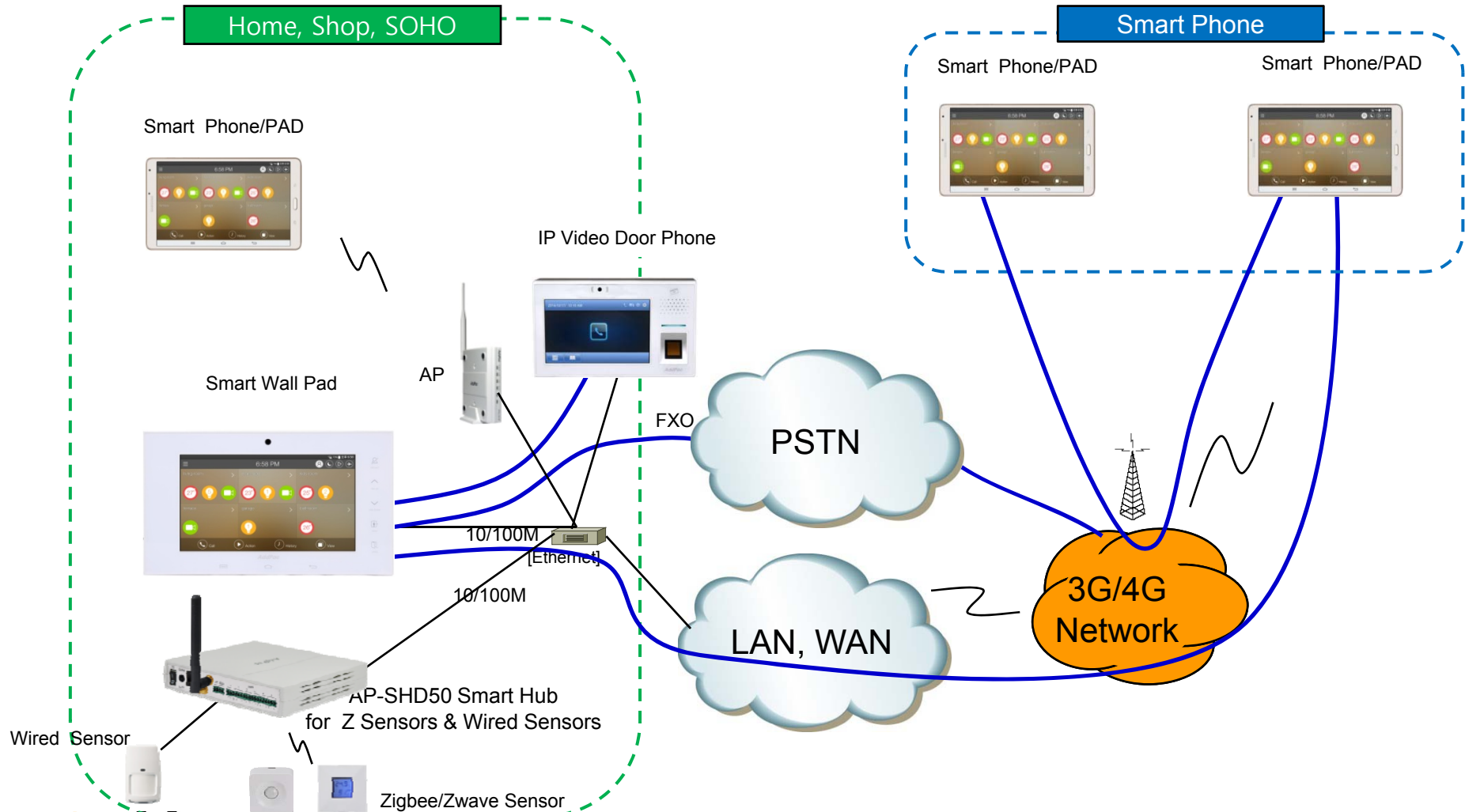

Smart Home Application

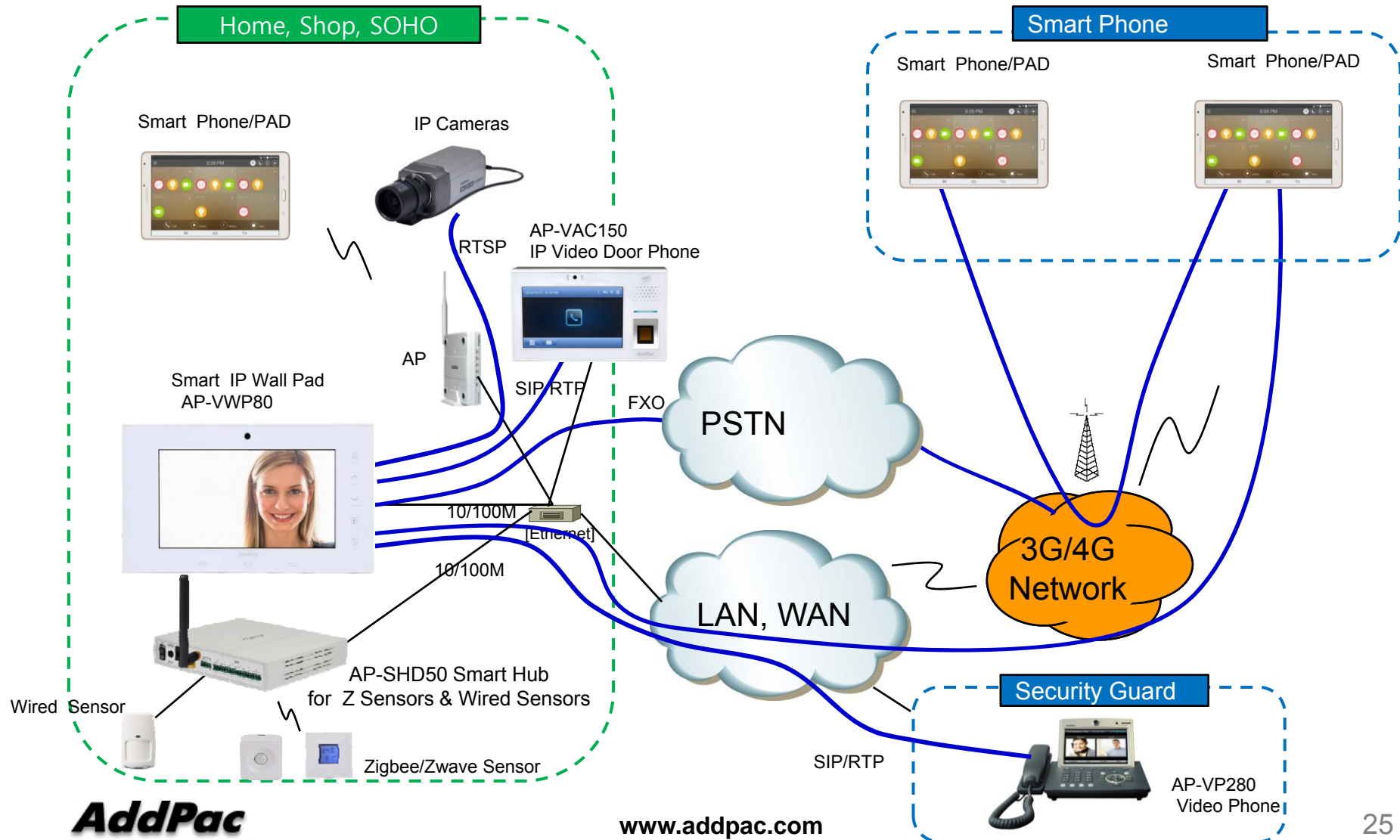

Ordering Information

- **AP-VWP80 IP Video Wall PAD Hardware**
 - AP-VWP80 IP Video Wall PAD Main Body
 - RISC Microprocessor with High-end Programmable DSP Architecture
 - 7 Inch LCD with Touch Screen Features
 - Internal MIC, Internal Speaker
 - 1-ports 10/100Mbps Fast Ethernet
 - PoE Interface (Option)
 - Including Network Cable Set & Internal Power Supply, etc.
- **Built-in APOS Internetworking Software for AP-VWP80**
- **Including 1 Year Hardware Warranty**
- **Product Documents**
 - Install and Operation Guide (PDF)
- **Pricing**
 - AddPac Technology Regional Sales Manager
 - Authorized Sales and Marketing Representatives
 - Please Contact www.addpac.com



Thank you!

AddPac Technology Co., Ltd.
Sales and Marketing

Phone +82.2.568.3848 (KOREA)

FAX +82.2.568.3847 (KOREA)

E-mail sales@addpac.com